

# EQUESTRIAN SPORTS NEW ZEALAND



## Section Four

### **RULES FOR EVENTING**

Incorporating NZPCA Horse Trials Competition Rules

Effective 1 August 2014  
Version 5.2

(c) Copyright 2014  
Equestrian Sports New Zealand

These Rules & Regulations cannot be reproduced in whole, or in part without the permission of the Equestrian Sports New Zealand.

These Rules & Regulations cannot be used either in principle, in whole, or in part for the judging of competition unless the Organising Committee or body is affiliated to Equestrian Sports New Zealand.

Equestrian Sports New Zealand  
PO Box 6146  
Marion Square  
Wellington 6141  
Phone: 04 499 8994  
Fax: 04 499 2899  
nzef@nzequestrian.org.nz  
Web site [www.nzequestrian.org.nz](http://www.nzequestrian.org.nz)

Federation Equestre Internationale  
Web site [www.fei.org](http://www.fei.org)

New Zealand Pony Clubs Association  
PO Box 8626  
Havelock North 4157  
Phone: 06 873 5464  
Fax: 06 873 5464  
nzpony@xtra.co.nz  
Web site [www.nzpca.org](http://www.nzpca.org)

# CONTENTS

HOW TO USE THIS BOOK .....	6
INTRODUCTION .....	7
Article 601 – DEFINITION (500.1) .....	7
Article 602 – RESPONSIBILITY (500.2.1) .....	7
Article 603 – ESNZ EVENTS (500.2.2).....	7
Article 604 – REGISTRATION OF HORSES (500.2.4).....	7
Article 605 – LEVIES .....	8
Article 606 – INTERPRETATION.....	8
GENERAL .....	9
Article 607 – CATEGORIES OF EVENTS (501).....	9
Article 608 – APPLICATIONS TO HOLD EVENTS.....	9
Article 609 – SPONSORSHIP OF EVENTS .....	9
Article 610 – DISCLAIMER OF LIABILITY .....	10
Article 611 – RESERVATION OF RIGHT .....	10
Article 612 – TELEVISION - FILM AND VIDEO RIGHTS .....	10
Article 613 – CLASSES (503).....	10
Article 614 – PARTICIPATION (503).....	11
Article 615 – ATHLETE RIDING MORE THAN ONE HORSE (504.1) .....	12
ADMINISTRATION.....	13
Article 616 – SCHEDULES (507.1).....	13
Article 617 – PROGRAMMES.....	13
Article 618 – OWNERS.....	14
Article 619 – PRIZES (505) .....	14
Article 620 – PRESENTATION OF PRIZES .....	14
Article 621 – RESULTS .....	14
OFFICIALS.....	15
Article 622 – JURISDICTION OF OFFICIALS (510).....	15
Article 623 – JUDGES (510).....	15
Article 624 – GROUND JURY (510, 513, 515) .....	16
Article 625 – APPEAL COMMITTEE (513.6) .....	17
Article 626 – TECHNICAL DELEGATE (510, 513, 515) .....	17
Article 627 – COURSE DESIGNER (510, 513, 515).....	18
Article 628 – STEWARDS (510, 513, 515) .....	19
Article 629 – OFFICIALS .....	19
Article 630 – ESNZ EVENTING TECHNICAL ADVISORS .....	20
Article 631 – APPOINTMENT OF OFFICIALS .....	20
Article 632 – OFFICIALS EDUCATION .....	21
TECHNICAL REQUIREMENTS .....	22
Article 633 – MINIMUM ELIGIBILITY REQUIREMENTS FOR HORSE AND ATHLETE (516-522).....	22
ATHLETES AND HORSES WELFARE .....	24
Article 634 – ATHLETES WELFARE (523).....	24
Article 635 – MINIMUM STANDARDS FOR MEDICAL PERSONNEL AND SERVICES AT EVENTS (Annex D).....	24
Article 636 – INSPECTION AND EXAMINATION OF HORSES (524) .....	26
Article 637 – MINIMUM STANDARDS FOR VETERINARY SERVICES AT EVENTS .....	28
Article 638 – DESTRUCTION OF SEVERELY INJURED HORSES.....	29
Article 639 – DANGEROUS RIDING (525).....	29

Article 640 – ABUSE OF HORSE (526).....	30
GENERAL COMPETITION RULES.....	32
Article 641 – CLASSIFICATION (528).....	32
Article 642 – DISQUALIFICATION (528).....	33
Article 643 – ENTRIES.....	33
Article 644 – DOUBLE ENTRY.....	34
Article 645 – EXCESSIVE ENTRIES AND BALLOTING.....	34
Article 646 – WITHDRAWALS AND SUBSTITUTIONS (530).....	35
Article 647 – STARTING (533).....	35
Article 648 – TIMETABLE (534).....	36
Article 649 – INDIVIDUAL AND TEAM COMPETITION.....	37
Article 650 – ORDERS.....	37
Article 651 – NUMBERS (535.1).....	37
Article 652 – EXERCISING AND WARMING UP (535.2).....	37
Article 653 – ACCESS TO COURSES & ARENAS (536).....	38
Article 654 – INTERRUPTIONS AND MODIFICATIONS (537).....	39
Article 655 – DRESS (538).....	40
Article 656 – SADDLERY (539).....	42
Article 657 – UNAUTHORISED ASSISTANCE (540).....	44
DRESSAGE TEST.....	45
Article 658 – RULES FOR DRESSAGE TEST (542).....	45
Article 659 – TEST (542.1).....	45
Article 660 – JUDGES POSITION (542.3).....	45
Article 661 – SCORING (544).....	46
Article 662 – ARENA.....	47
CROSS COUNTRY TEST.....	48
Article 663 – RULES GOVERNING THE CROSS COUNTRY TEST (544).....	48
Article 664 – COURSES (546).....	50
Article 665 – OBSTACLES (547).....	51
Article 666 – SCORING (548).....	54
Article 667 – DEFINITIONS OF FAULTS (549).....	55
JUMPING TEST.....	58
Article 668 – RULES FOR JUMPING TEST (550).....	58
Article 669 – OBJECT & GENERAL DESCRIPTION (551).....	58
Article 670 – SIZE OF ARENA.....	58
Article 671 – COURSE - OBSTACLES (552).....	58
Article 672 – SCORING (553).....	59
Article 673 – TIME CORRECTIONS.....	60
SPECIAL COMPETITIONS.....	61
Article 674 – NEW ZEALAND ONE DAY EVENT CHAMPIONSHIPS.....	61
Article 675 – NEW ZEALAND YOUNG RIDER AND JUNIOR RIDER ONE DAY EVENT CHAMPIONSHIPS.....	61
Article 676 – NEW ZEALAND THREE DAY EVENT CHAMPIONSHIPS....	61
Article 677 – INTER-ISLAND TEAMS COMPETITION.....	62
Article 678 – NEW ZEALAND YOUNG RIDER AND JUNIOR RIDER THREE DAY EVENT CHAMPIONSHIPS.....	63
ANNEX 1 SADDLERY.....	64
PERMITTED BITS FOR THE DRESSAGE TEST.....	64
DRAWINGS PERMITTED BITS.....	65
DRAWINGS PERMITTED SNAFFLES.....	67

PERMITTED NOSEBANDS FOR THE DRESSAGE TEST .....	68
ANNEX 2 ONE DAY EVENTS.....	71
ANNEX 2 ONE DAY EVENTS.....	72
ANNEX 3 THREE DAY EVENTS .....	73
ANNEX 4 XC FAULTS .....	74
ANNEX 5 NZPCA.....	77
INTRODUCTION .....	77
Article 626 – TECHNICAL DELEGATE .....	77
Article 635 – MINIMUM STANDARD FOR MEDICAL PERSONNEL AND SERVICES AT EVENTS.....	77
Article 637 – MINIMUM STANDARDS FOR VETERINARY SERVICES AT EVENTS .....	78
Article 639 – DANGEROUS RIDING .....	78
Article 640 – ABUSE OF HORSE .....	79
Article 655 – DRESS .....	79
Article 656 – SADDLERY .....	79
Article 655 – DRESS & Article – 656 SADDLERY .....	79
Article 665 – OBSTACLES .....	80
Article 666 – SCORING .....	80
INDEX .....	81

## **HOW TO USE THIS BOOK**

The number appearing in brackets at the end of some article names, are the Article number for the FEI Rules for Eventing (500 series).

Over time, more rules will be brought into line with the FEI Rules for Eventing. This will make the transition from National Events to International Events for Athletes easier as the rules will be the same in most cases.

CONCOURS COMPLET D'EQUITATION INTERNATIONAL (CCI) - events where the competitions are exclusively for International Three Day Events.

CONCOURS INTERNATIONAL COMBINE (CIC) - events where the competitions are exclusively for International One Day Events.

CONCOURS COMPLET D'EQUITATION NATIONAL (CCN) - events where the competitions are exclusively for National Three Day Events.

CONCOURS NATIONAL COMBINE (CNC) - events where the competitions are exclusively for National One Day Events.

# EQUESTRIAN SPORTS NEW ZEALAND

## RULES FOR EVENTING

### CHAPTER I INTRODUCTION

#### **Article 601 – DEFINITION (500.1)**

An Eventing Competition consists of three distinct tests during which an Athlete rides the same Horse throughout, namely: Dressage, Cross Country and Jumping.

#### **Article 602 – RESPONSIBILITY (500.2.1)**

Making an entry for any Event run by or on behalf of ESNZ Eventing under the ESNZ Rules for Eventing or FEI Rules for Eventing constitutes implicit acceptance of the ESNZ Regulations and Rules for Eventing or of the FEI Regulations and Rules for Eventing, where applicable, and binds the entrant to abide by them.

The appointment of a Steward or Official, whether or not provided for in these Eventing Rules, does not absolve the Athlete from such responsibility. For any circumstances not specifically covered in these rules reference should be made to the F.E.I. Rules for Eventing. In any unforeseen or exceptional circumstances it is the duty of the officials responsible to make a decision in a sporting spirit in accordance with the intention of these rules.

\* refer to NZPCA Annex 5 \*

#### **Article 603 – ESNZ EVENTS (500.2.2)**

The Equestrian Sports New Zealand Events are those held under the rules contained in this book are either:

Events financed by and organised on behalf of ESNZ Eventing, or Affiliated Events financed and organised by an individual or body affiliated to Equestrian Sports New Zealand.

#### **Article 604 – REGISTRATION OF HORSES (500.2.4)**

1. All Horses must be registered with NF before being entered for any Event run by ESNZ Eventing or run under ESNZ Rules for Eventing, with the exception of CNC 65 classes and Express Eventing/Practice Days for which Horses do not need to be registered. For full details see ESNZ General Regulations.

2. Infringement of any registration rule may be penalised by a fine not exceeding \$200.00 and/or three months suspension.

### **Article 605 – LEVIES**

1. Levies will be set by the ESNZ Eventing Board.
2. Levies are payable for any class or event run under ESNZ Rules for Eventing or FEI Rules for Eventing.
3. Levies will be collected on behalf of ESNZ Eventing by the OC for all Athletes starting the Dressage Test.

### **Article 606 – INTERPRETATION**

'F.E.I.' refers to the Federation Equestre Internationale.

'Events' shall include all types of Eventing competition - One and Three Day Events where applicable.

'ESNZ' refers to Equestrian Sports New Zealand.

'ESNZ Eventing' refers to a discipline of Equestrian Sports New Zealand.

'Organiser' refers to the person, group, committee or association responsible for the organisation of an Event.

'An Event' refers to the complete meeting run by the Organiser. It extends from one hour before the beginning of the first Horse inspection, or the start of the first competition whichever is the earlier, until half an hour after the announcement of the final results, unless the Schedule provides otherwise.

Reference to the male gender includes all genders.

Reference to Horses include Ponies unless otherwise stated.



# CHAPTER II

## GENERAL

### Article 607 – CATEGORIES OF EVENTS (501)

The types of Events are as follows:

1. **ONE DAY EVENTS** comprises the same three tests of a Three Day Event. The event may take place over 1, 2 or even 3 days. The Dressage Test always takes place first. Either the Cross Country or the Jumping may form the last test.
2. **THREE DAY EVENTS** comprises three distinct tests, taking place on separate days, during which an Athlete rides the same Horse throughout, namely:
  - 2.1 **Dressage** - A Dressage Test spread over one or more consecutive days, depending on the number of Athletes, directly followed on the next day by:
  - 2.2 **Cross Country** - A Cross Country Obstacles Test.  
The Cross Country will be directly followed on the next day by:
  - 2.3 **Jumping** - A Jumping Test.

### Article 608 – APPLICATIONS TO HOLD EVENTS

1. All applications to hold an Eventing event must be made in writing to the Sport Manager of ESNZ Eventing for approval by the ESNZ Eventing Board. The ESNZ Eventing Board reserves the right to refuse approval. Once an Event has been approved, the Organiser must comply with the ESNZ Eventing Rules for Eventing.
2. An application to approve an Event at a new venue is to be referred first to the ESNZ Eventing Board and secondly to the Technical Committee who will appoint a Technical Advisor to inspect the proposed new venue to assess its suitability for an Event and if approved by the ESNZ Eventing Board will then be referred to the Sport Manager to negotiate the date and classes.

### Article 609 – SPONSORSHIP OF EVENTS

Sponsorship agreements entered into by ESNZ Eventing for the benefit of the Sport of Eventing must be honoured by each Eventing Organiser. Organisers must obtain approval from the Chairman of ESNZ Eventing for each sponsorship agreement in excess of \$5,000.00 before it is finalised to ensure that it does not conflict with a national sponsorship agreement.

## **Article 610 – DISCLAIMER OF LIABILITY**

Neither the Organiser of any event to which these rules apply nor the NF nor any agent, employee or representative of these bodies accepts any liability for any accident, loss, damage, injury or illness to Horses, owners, Athletes, spectators, land, vehicles, their contents and accessories or any other personal property whatsoever whether caused by their negligence, breach of contract, or in any other way whatsoever.

## **Article 611 – RESERVATION OF RIGHT**

The Organiser reserves the right:

1. To cancel any class or event.
  2. To divide any class and amend prize money accordingly.
  3. To alter the advertised times.
  4. To refuse any entry (with or without stating a reason).
  5. To transfer Athletes between sections of a class.
  6. To alter or amend the programme as the Organiser sees fit.
- Reference to this reservation should be printed in the schedule and programme.

## **Article 612 – TELEVISION - FILM AND VIDEO RIGHTS**

Any proposed contract or agreement between or on behalf of the Organiser of any Events for which a fee is payable must be submitted for approval by the ESNZ Eventing Board.

## **Article 613 – CLASSES (503)**

An Event may, subject to the approval of the ESNZ Eventing Board, run all or any of the following classes:

1. CNC 3\* Class - Open to Horses with the required CNC 3\* MER and run under CNC 3\* conditions.
2. CNC 2\* Plus Class - Open to Horses with required CNC 2\* MER. Dressage and Jumping is of CNC 3\* level, Cross Country of CNC 2\* level.
3. CNC 2\* Class - Open to Horses with the required CNC 2\* MER and run under CNC 2\* conditions.
4. CNC 1\* Plus Class - Open to Horses with required CNC 1\* MER. Dressage and Jumping is of CNC 2\* level, Cross Country of CNC 1\* level.
5. CNC 1\* Class - Open to Horses with the required CNC 1\* MER and run under CNC 1\* conditions.
6. CNC105 Plus Class - Open to all Horses. Dressage of CNC 1\* level, Jumping is of CCN105 level, Cross Country of CNC105 level.

7. CNC105 Class - Open to all Horses and run under CNC105 conditions.
8. CNC95 Class - Open to all Horses and run under CNC95 conditions.
9. CNC80 Class - Open to all Horses and run under CNC80 conditions.
10. CNC65 Class - Open to all Horses and run under CNC65 conditions.
11. Classes may be restricted to a particular category of Horses or Athletes. i.e. Pony, Junior, Young Rider, Veteran.

## **Article 614 – PARTICIPATION (503)**

### **1. Athletes:**

Athletes entered in Events for Horses run under ESNZ Rules for Eventing:

- 1.1 Must be financial member of the ESNZ with the exception of:
  - a) Athletes who are competing in CNC65 classes and/or Express Eventing/Practice Days who must be Community members; or
  - b) Athletes who are competing in New Zealand as members of a visiting national representative team;
- 1.2 Foreign Athletes must become members of ESNZ whilst competing at National events in New Zealand.
- 1.3 May compete at One Day Event classes and Three Day Event classes at 1\* and above from the beginning of the calendar year of their fourteenth birthday.
- 1.4 May compete in One Day Event classes at CNC105 and below regardless of age.
- 1.5 May compete in Three Day Events at CNC95 and CNC105 from the beginning of the calendar year of their tenth birthday.
- 1.6 May compete in Young Rider classes if under 21 years at 1<sup>st</sup> January of that year.
- 1.7 May compete in Junior Rider classes if under 18 at 1<sup>st</sup> January of that year.

### **2 Horses:**

- 2.1 All Horses, with exception of:
  - a) Horses competing only in Training Events, or
  - b) Foreign Horses competing in New Zealand in a national representative team;
 must be currently registered with ESNZ Eventing.
- 2.2 A Horse must be four years of age or over based on the official foaling date of 1st August to compete in CNC105 Classes and below.
- 2.3 A Horse must be five years of age or over based on the official foaling date of 1st August to compete in a CNC 1\*.
- 2.4 A Horse, from the beginning of the calendar year in which the Horse reaches the age of six, may compete in a CNC 2\* or above.

- 2.5 Senior, Young Rider and Junior One and Three Day Events are open equally to Horses and Ponies, provided they and their Athletes meet all the relevant qualifications.

**Article 615 – ATHLETE RIDING MORE THAN ONE HORSE (504.1)**

1. There is no limitation to the number of Horses an Athlete may ride in an individual competition, class or division of a class, with the following exceptions:
  - 1.1 The Organising Committee may impose a limitation, in its absolute discretion, whether for time-tabling or any other reason.
  - 1.2 Where any event has more entries than it can accommodate, no Athlete may ride more than two Horses (or one Horse if so decided by the OC).
2. Where an Athlete has a Horse in a team competition, he must always ride that Horse before a Horse in the individual competition.

# CHAPTER IV

## ADMINISTRATION

### **Article 616 – SCHEDULES (507.1)**

1. The Schedule for an Event must be published by the Organiser not less than four weeks before the closing date of entries. It is not necessary to repeat the rules contained in this Rule Book, but it should include the following:
  - 1.1 Statement that the Event is held under the ESNZ Rules for Eventing, or where applicable, the FEI Rules for Eventing.
  - 1.2 Place and date of event.
  - 1.3 Classes to be held.
  - 1.4 Name and address of Event Secretary.
  - 1.5 Approximate timetable.
  - 1.6 Dressage Test, entry fee and prizes for each class.
  - 1.7 Closing date and conditions of entry.
  - 1.8 Cross Country information including the time at which the course will be open for inspection or the time of the Athletes' briefing.
  - 1.9 Method of notification of draw or start times.
  - 1.10 Administrative arrangements such as stabling, accommodation.
  - 1.11 Whether dogs are permitted on grounds.
  - 1.12 Whether presentation is mounted.
  - 1.13 Whether a waiting list is held.
  - 1.14 Print in full Article 610 - Disclaimer of Liability.
  - 1.15 Reference only to Article 611 - Reservation of Right.

### **Article 617 – PROGRAMMES**

1. All programmes should include the following:
  - 1.1 A statement that the Event is held under ESNZ Rules for Eventing, or where applicable, the FEI Rules for Eventing.
  - 1.2 Timetable of classes and tests.
  - 1.3 List of entries with score sheet.
  - 1.4 List of Officials, including Organiser, Technical Delegate, Ground Jury, Stewards, Veterinary and Medical Officers.
  - 1.5 Whether presentation is mounted.
  - 1.6 Print in full Article 610 - Disclaimer of liability.
2. Programmes for One Day Events may include a plan of the Cross Country Course with distance and optimum time and time limit for each class.
3. Programmes for all Events may include:
  - 3.1 Advice on admissibility of dogs and instruction that dogs, when permitted, must be kept on leads.

- 3.2 Rules on unauthorised assistance.
- 3.3 Brief rules and system of scoring.

### **Article 618 – OWNERS**

Organisers of Events should provide one pass for one owner of each Horse.

### **Article 619 – PRIZES (505)**

There must be not less than two Athletes taking part in any class for any prize to be awarded. Prizes will be awarded in a ratio of not less than one prize to every five starters; i.e. Between 2-5 starters at least one prize must be awarded etc. The number of starters is determined by the number of Athletes starting in the Dressage Test of the class. Also refer to ESNZ General Regulations.

### **Article 620 – PRESENTATION OF PRIZES**

In most cases, prizes will be presented to the winning Athletes unmounted, but Athletes must be correctly attired as for the Jumping Test. If Organisers require Athletes to be mounted for the presentation of prizes then this must be stated in the Schedule and Programme. Each prize must be collected by the winner in person. The organiser may permit a prize to be received by a suitable deputy. Any prize not collected by the winner or the agreed suitable deputy shall be forfeit at the discretion of the Organising Committee.

### **Article 621 – RESULTS**

The results of any Event must be sent to the Sport Manager ESNZ Eventing immediately after the event together with a copy of the master score sheet for each class.

# CHAPTER IV OFFICIALS

## **Article 622 – JURISDICTION OF OFFICIALS (510)**

The period of an event commences one hour before the beginning of the 1st Horse Inspection and terminates half an hour after the announcement of the final results.

However, the jurisdiction of the Ground Jury commences when they inspect and approve the Cross Country course, or at the First Horse Inspection, or one hour prior to the start of the Dressage Test, whichever is earlier.

## **Article 623 – JUDGES (510)**

Judges must be appointed from the ESNZ Dressage Judges' List as follows and from the FEI List of Eventing judges ( who may judge any class.) -

### **1. DRESSAGE.**

Judges must be appointed from the ESNZ Dressage Judges' List as follows and from the FEI List of Eventing Judges (who may judge any class) -

- 1.1 At New Zealand Championship Events and at Three Day Events: Two judges from Lists 1 to 3. One shall be a List 1 or a List 2 Judge (or FEI Eventing Judge).
- 1.2 At One Day Events:  
CNC105/105 Plus Class/1\* Class/1\*Plus Class: It is recommended that there be two judges where possible, one may be from List 5 OR One judge from Lists 1 to 4. 2\* Class/2\*Plus Class/3\* Class: Two Judges from Lists 1 to 4.
- 1.3 Classes below 105: One Judge may be list 5.

### **2. CROSS COUNTRY**

There must be Chief Cross Country Judge and one or two Assistant Cross Country Judges for all Events to supervise the fence judges, starter, timekeeper, scorers and other officials connected with the Cross Country Test. These Judges must be taken from the current ESNZ Cross Country Judge List and/or the FEI list of Eventing Judges.

### 3. **JUMPING**

There must be two Judges taken from the current ESNZ list of Jumping Judges and/or FEI list of Eventing Judges, one of whom must be a ESNZ National Jumping Judge.

4. Where possible at least one Judge shall judge all tests in each competition in Three Day Events.

### **Article 624 – GROUND JURY (510, 513, 515)**

1. In all Events run under ESNZ Rules there will be a Ground Jury. The President of the Ground Jury will be the Chief Cross Country Judge. The members will be the Assistant Cross Country Judge(s).
2. The Chief Judge of the Dressage or Jumping test of the class, or division of a class, will become a member of the Ground Jury for matters pertaining to their respective test.
3. The Ground Jury is ultimately responsible for the judging of the competition and for settling all problems that may arise during its jurisdiction. Together with the Technical Delegate, Course Designer and Organiser, it shall endeavour to ensure that all arrangements for the competition, including the arenas, courses and obstacles, are appropriate. If after consultation with the Technical Delegate, the Ground Jury is not satisfied with the arrangements of courses, it is authorised to modify them.
4. The Inspection Committee for the first and third inspections at a Three Day Event shall comprise the President and at least one other member of the Ground Jury and the Official Veterinarian with the President of the Ground Jury in charge.
5. During the Cross Country Test of a Three Day Event a member of the Ground Jury will be based at the Control Centre to adjudicate any unforeseen eventualities. Another member of the Ground Jury or his nominee together with the Official Veterinarian will form the Committee for the second inspection of Horses and will be based at the end of the Cross Country Course.
6. The Ground Jury for the Cross Country Test will be responsible for determining Protests against decisions by technical personnel, including fence judges and timekeepers, on the Cross Country Test and may substitute their judgement for that of any Judge or Official, whether in favour of the Athlete or not.
7. Any member of the Ground Jury shall have the duty and full authority at any time during the competition to eliminate from the competition any Horse that is lame, sick or exhausted and any Athlete that is unfit to continue. There is no appeal against such a decision.
8. The Ground Jury may not order a competition to start until the Technical Delegate has reported that the course is ready. Thereafter



the Ground Jury is solely responsible for the conduct of the competition.

9. The period of jurisdiction of a Ground Jury extends from one hour before the start of the Event or Test until half an hour after the announcement of the results of the competition or test for which the Ground Jury has been appointed. If a Protest is made during the period of jurisdiction the Ground Jury remains responsible until the Protest has been settled.
10. The following may not service on the Ground Jury at an Event:
  - 10.1 the Technical Delegate,
  - 10.2 the Course Designer,
  - 10.3 An Athlete taking part in the competition,
  - 10.4 Chefs d'Equipe,
  - 10.5 Team Officials whose Athletes are entered in the competition,
  - 10.6 The Official Veterinarian,
  - 10.7 The Appeal Committee appointed for the competition,
  - 10.8 Any person who may be subject to a conflict of interest, and
  - 10.9 The owner of a Horse taking part in the Event.

\* refer to NZPCA Annex 5 \*

#### **Article 625 – APPEAL COMMITTEE (513.6)**

An Appeal Committee will be approved by the ESNZ Eventing Board for all New Zealand Championship Events run under ESNZ Rules. For all other Events it is not compulsory to appoint an Appeal Committee.

#### **Article 626 – TECHNICAL DELEGATE (510, 513, 515)**

1. An ESNZ Eventing Technical Delegate, a Level 3&4\* International Technical Delegate or a Level 1/2\* Technical Delegate will be approved by the ESNZ Eventing Board for all New Zealand Championship Events and Three Day Events on the recommendation of the Organiser. The Technical Delegate so appointed for a Three Day Event must have had previous experience as a Technical Delegate or an Assistant Technical Delegate at a Three Day Event. For all other Events it is the responsibility of the Organiser to appoint a Technical Delegate.
  - 2.1 A Technical Delegate must be selected from the current ESNZ List of Technical Delegates for Eventing or be on the FEI List of Technical Delegates.
  - 2.2 An Assistant Technical Delegate must be selected from the current ESNZ List of Technical Delegates for Eventing or be on the FEI List of Technical Delegates.
  - 2.3 A Technical Delegate shall be appointed to officiate at one event for a maximum of 3 consecutive years.

- 2.4 A Technical Delegate and Assistant Technical Delegate shall not officiate at more than 3 levels per event.
3. The powers, duties and responsibilities of a Technical Delegate are as follows:
  - 3.1 The Technical Delegate will approve the technical and administrative arrangements for the conduct of the Event; for the examinations and inspections of Horses; for the accommodation of Horses and Athletes; and for the stewarding of the Event.
  - 3.2 For all three tests, he will inspect and approve the courses, arenas and facilities for exercising and training, including the type and dimension of obstacles and the measurement of all courses, with particular reference to their suitability for the level of the event. Technical Delegates are specifically required to measure all courses to ensure they are of the indicated distances. He must be able to inspect early enough to allow for modifications to be made. He may request one or more Horses to try out any part of the arenas or courses or any obstacles.
  - 3.3 He will supervise the briefing and conduct of all technical personnel.
  - 3.4 He will investigate all enquiries regarding scoring, including penalties awarded and report to and advise the Ground Jury on any decisions they are required to make.
  - 3.5 Until he has reported to the Ground Jury that he is satisfied with all the arrangements, the authority of the Technical Delegate shall be absolute. Thereafter he will continue to supervise the technical and administrative conduct of the Event and will advise and assist the Ground Jury, Chief Steward, Official Veterinarian and the Organiser.

\* refer to NZPCA Annex 5 \*

#### **Article 627 – COURSE DESIGNER (510, 513, 515)**

1. Course Designers will be approved by the ESNZ Eventing Board on the recommendation of the Organiser for all Three Day Events and for all NZ Championship Events and by the Organiser for all other events from the current ESNZ and FEI lists of Course Designers for Eventing.
2. The Course Designer appointed by the Organiser is responsible for the layout, measurement, preparation and marking of the route of the Cross Country test.
3. He is responsible for the design, construction and marking of the obstacles on the Cross Country Test.
4. He is ultimately responsible for the layout, design and construction of the Jumping Test. This duty may be delegated to a Jumping Course Designer but the Event Course Designer must ensure that the course is suitable for Eventing.

5. He shall report to the Technical Delegate when he is satisfied that the course is ready in all respects.
6. If an obstacle has to be rebuilt during a competition, he must report to the Technical Delegate or the President of the Ground Jury that the obstacle is rebuilt in accordance with the specifications approved for the obstacle.
7. The Course Designer must be present during the event's Cross Country test he is responsible for. If for any serious reason, the appointed Course Designer cannot be present, a qualified CD of at least Level 2 or above, familiar with the course, can be appointed to replace him.

#### **Article 628 – STEWARDS (510, 513, 515)**

1. At all events run under ESNZ rules, a Chief Steward, and such assistant stewards as are necessary, will be appointed. At One Day Events, the Chief Steward may be an ESNZ Eventing Steward. For all Three Day Events, they must be an FEI Eventing Steward.
2. It is the responsibility of the Organising Committee to appoint the Stewards for all events. For New Zealand Championship Events, the appointment of the Chief Steward must be approved by the Board of ESNZ Eventing.
3. The Stewards are responsible to ensure that the general welfare of the Horses is looked after, and in particular to ensure that the rules regarding exercise and warming up are obeyed. Gear Inspectors, if appointed, will be under the control of the Chief Steward.
4. A Steward must be present whenever the practice obstacles are being used. Other practice and exercise areas, and the stables and truck park, may be patrolled by Stewards in a random manner.

#### **Article 629 – OFFICIALS**

1. The ESNZ Eventing Board will approve -
  - 1.1 The Judges for all New Zealand Championship Events on the recommendation of the Organiser.
  - 1.2 The Technical Delegate for all New Zealand Championship and Three Day Events on the recommendation of the Organiser.
2. The Organiser will appoint -
  - 2.1 All other Officials at New Zealand Championship and Three Day Events.
  - 2.2 The Officials at all other Events.
3. Medical - Refer to Article 635 for presence of medical personnel during the Event.

4. Veterinary - The Organiser must appoint a Veterinarian to be the Official Veterinarian for the Event. Refer to Article 637 for presence of Veterinarian during an Event.
5. The Chief Steward for all New Zealand Championship Events on the recommendation of the Organiser.

#### **Article 630 – ESNZ EVENTING TECHNICAL ADVISORS**

1. The ESNZ Eventing Board will appoint Technical Advisors from the ESNZ list of Eventing Technical Delegates.
2. The Duties of the Technical Advisors include:
  - 2.1 To act as adviser or consultant to Technical Delegates, Organisers and Athletes.
  - 2.2 To act as liaison officer between Technical Delegates, Organisers and ESNZ Eventing Board on all matters pertaining to the organisation or conduct of an Event.
  - 2.3 To assist the Technical Committee in the approving and upgrading of Candidate Technical Delegates, Candidate Cross Country Judges and Candidate Course Designers and the approval of sites for Events.

#### **Article 631 – APPOINTMENT OF OFFICIALS**

<b>Class</b>	<b>Course Designer</b>	<b>Technical Delegate</b>	<b>Cross Country Judge</b>	<b>Stewards</b>
<b>CNC65</b>	May be Level 3	May be Level 3	May be Level 3	Shall be Level 3 or above
	One must be Level 2 or above			
<b>CNC80</b>	May be Level 3	May be Level 3	May be Level 3	Shall be Level 3 or above
	One must be Level 2 or above			
<b>CNC/CCN 95</b>	May be Level 3	May be Level 3	May be Level 3	Shall be Level 3 or above
	One must be Level 2 or above			
<b>CNC/CCN 105</b>	May be Level 3	May be Level 3	May be Level 3	Must be Level 2 or above
	Two must be Level 2 or above			

<b>Class</b>	<b>Course Designer</b>	<b>Technical Delegate</b>	<b>Cross Country Judge</b>	<b>Stewards</b>
<b>CNC/CCN 1*</b>	May be Level 3	May be Level 3	May be Level 3	Must be Level 2 or above
	Two must be Level 2 or above			
<b>CNC/CCN 2*</b>	One must be Level 1 and the other must be Level 2 or above		Must be Level 1	Must be Level 2 or above
<b>CNC/CCN 3*</b>	All Officials must be Level 1			

### **Article 632 – OFFICIALS EDUCATION**

Officials shall attend a National Seminar at least once every three years to maintain their accreditation level.

# CHAPTER VI

## TECHNICAL REQUIREMENTS

### Article 633 – MINIMUM ELIGIBILITY REQUIREMENTS FOR HORSE AND ATHLETE (516-522)

1. **Minimum Eligibility Requirement (MER)**

- 1.1 A qualifying result (MER) is achieved by completing a competition within minimum parameters of all round performance. As follows:
- not less than 50 percent in the Dressage Test; and
  - not more than 20 penalties at obstacles on the Cross Country Test, and not more than 90 seconds exceeding the optimum time in the Cross Country Test; and
  - not more than 16 penalties at obstacles in the Jumping Test.

2. **Qualifying Period and Deadline**

- 2.1 Qualifications must be obtained in the calendar year in question or the 2 preceding calendar years.
- 2.2 There are no dispensations for Qualifications.

3. **One Day Events (CNC)**

- 3.1 To enter a CNC1\* the Horse must have two MERs at CNC105 level, one of which must have 0 XC Jump Faults.
- 3.2 To enter a CNC 2\*, Horse and Athlete (not necessarily the same combination) must have two MERs of CNC 1\* level.
- 3.3 To enter a CNC 3\*, Horse and Athlete (not necessarily the same combination) must have two MERs of CNC 2\* level.

4. **Three Day Events (CCN)**

4.1 CCN105	CCN 1*
2 x CNC105 A Pony Club Area Trials or Championships or Springston Trophy senior class may be substituted for 1 x CNC105	2 x CNC 1* Level and 1 x CNC105, any one MER must have 0 XC Jump. or 1 x CNC 1* Level and 1 x CIC 1*

- 4.2 Organisers may impose additional qualifications for Horses which must be published in the Schedule for the event.
5. An Athlete / Horse combination having participated in an event without the appropriate qualifications will be disqualified from the specific event.

## 6. FEI Eligibility Requirements

Level	Athlete Type	NZ Athlete Minimum Eligibility Requirements	
CIC	1*	2 x CNC105, one must have 0 XC Jump Faults (Horse & Athlete, not necessarily the same combination)	
	2*	1 x CNC1* and 1 x C1*	
		D Athletes	1 x CNC1* (Horse only) and 1 x C1*
3*	A, B, C Athletes	1 x C1* (Horse only)	
	National, D & C Athletes	2 x C/2*	
1*	A & B Athletes	1 x C/2*	
	All Athletes	2 x CNC1* or 1 x CNC1* + 1 x CIC1* or 2 x CIC1* (Horse & Athlete, not necessarily the same combination) any one MER must have 0 XC Jump Faults.	
CCI	2*	1 x CC1* or 1 x CIC2* and 1 x CIC2*	
	3*	A, B, & C Athletes	1 x CC1* or 1 x CIC2*
		National, D & C Athletes	1 x CC2* and 1 x CIC3*
4*	A & B Athletes	1 x CC2*	
4*	National, B, C & D Athletes	1 x CC3* and 2 x C/3*	
	A Athletes	1 x CC3*	

### Notes

- Refer to FEI Eventing Rules, Chapter 5, Article 519 Athletes Categories for definitions and requirements of proven competence.
- Those Athletes that already have a FEI Athlete Categorisation (A,B,C,D) only have to achieve the corresponding MER for the horse at the level they are Categorised at. Those Athletes that are NOT categorised (National level) are required to achieve the required MER as a combination.
- Minimum Eligibility Requirements:
  - Dressage Test not more than 75 Penalty points
  - Cross Country –
    - A clear round (0 Penalties) or if more than one MER is required, one MER may be achieved with 20 Penalties.
    - Not more than 90 seconds exceeding the optimum time in the XC for 1, 2 and 3\* level competition and 120 seconds for 4\*
  - Jumping Test not more than 16 penalties at obstacles
- The requirements in *Italics* are those set by the FEI.

# **CHAPTER VII**

## **ATHLETES AND HORSES WELFARE**

### **Article 634 – ATHLETES WELFARE (523)**

1. All Athletes competing at Events run under ESNZ Rules must carry readily accessible on their person a Medical Card containing information of any relevant medical history of serious illness, injury (particularly to the head), tetanus immunity status, drug allergies, current medication and blood group. Such Medical Card must be carried on the Athlete's arm so that the Athlete's name is clearly visible at all times during the Jumping Test and Cross Country Test. Athletes may be required to present the medical card to the Organising Medical Officer at any stage during the event.
2. For the duration of the competition it is a requirement that an Athlete ensures that they have no current medical condition (e.g. concussion) that may adversely affect their ability to compete safely.
3. An Athlete may not compete or participate mounted in any Event run under ESNZ Eventing Rules for a minimum of 21 days following concussion. After this compulsory 21 day stand down a medical clearance to resume riding must be obtained by the Athlete before they ride in a competition.
4. All Athletes who have had a fall during training on the Competition site or in Competition must be examined by the official Medical officer before they either take part in another test, Competition or leave the venue. The Athlete is fully responsible for ensuring that this examination takes place.

### **Article 635 – MINIMUM STANDARDS FOR MEDICAL PERSONNEL AND SERVICES AT EVENTS (Annex D)**

1. **Prior to the Event**  
Organisers:
  - 1.1 Must notify the regional Ambulance Control Room for the area of the date and location of the event and explain the potential accidents that can occur at such as event.
  - 1.2 Should provide a centrally sited medical station.
  - 1.3 Must ensure that there is good access to all parts of the course.
2. **During the Event**  
The following is the minimum standards of Medical Care required at an Eventing event



Advanced Paramedic	All of the below plus laryngoscopy, endotracheal intubation, cricothyroidotomy, chest decompression, intraosseus needle access, adrenaline, atropine, frusemide, amiodarone, midazolam, ketamine
Paramedic	All of the below plus IV cannulation, fluid administration glucose, Manual Defibrillation, IV pain relief, IV anti nausea
Ambulance Officer	All of the below plus LMA airway, nasopharyngeal airway, nebulised salbutamol, GTN, glucagon
Primary Care	AED, methoxyflurane, aspirin, paracetamol
Doctor	A qualified doctor who holds a current trauma certificate and who will bring the relevant equipment and drugs to carry out the duties of a paramedic.
Ambulance	The following equipment must be present; standard stretcher, scoop stretcher, KED, traction splint, c collars, suction unit, oxygen and masks, IV equipment, sharps container, Defibrillator with monitoring, BP Cuff, first response kit per officer that contains all the relevant drugs and equipment required for that skill level
Rapid Response Vehicle	This vehicle must be able to access all of the course and can be provided by the organisers. It is aimed at getting first response to an accident with first response trauma equipment and officer.

<b>Dressage</b>				
Highest level of competition	Officer 1	Officer 2	Officer 3	Vehicle
FEI Events	Paramedic	Primary Care or First Aid	Nil	Ambulance
All National Classes	Ambulance Officer	Primary Care or First Aid	Nil	Ambulance

<b>Cross Country Option 1</b>				
Highest level of competition	Officer 1	Officer 2	Officer 3	Vehicle
FEI Events	Advanced Paramedic	Ambulance Officer	Primary Care or First Aid	Ambulance and Rapid Response
CNC 1* - 3*	Paramedic	Primary Care or First Aid	Nil	Ambulance and Rapid Response
CNC/CCN 105 and Below	Ambulance Officer	Primary Care or First Aid	Nil	Ambulance

<b>Cross Country Option 2</b>				
Highest level of competition	Officer 1	Officer 2	Officer 3	Vehicle
FEI Events CNC 1* - 3*	Doctor	Ambulance Officer	Nil	Ambulance and Rapid Response
CNC/CCN 105 and Below	Doctor	Primary Care	Nil	Ambulance

<b>Jumping Option 1</b>				
Highest level of competition	Officer 1	Officer 2	Officer 3	Vehicle
FEI Events CNC 1* - 3*	Paramedic	Primary Care or First Aid	Nil	Ambulance
CNC/CCN 105 and Below	Ambulance Officer	Primary Care or First Aid	Nil	Ambulance

<b>Jumping Option 2</b>				
Highest level of competition	Officer 1	Officer 2	Officer 3	Vehicle
FEI and All National Classes	Doctor	Ambulance Officer	Nil	Ambulance

\* refer to NZPCA Annex 5 \*

## **Article 636 – INSPECTION AND EXAMINATION OF HORSES (524)**

### **1. Three Day Events**

#### **1.1. Examination upon Arrival**

This takes place on the arrival of Horses at the stables of the event. It is performed by a qualified veterinarian, normally the Associate Veterinarian, appointed by the Organising Committee. The object is to establish first each Horse's identity and veterinary history (vaccination, etc.) and second, each Horse's state of health (but not its soundness). The Organising Committee must fix the place and timetable for this examination in agreement with the Veterinary Delegate and inform in advance the Chefs d'Equipe and/or the individuals. Doubtful cases must be reported to the Ground Jury or Appeal Committee as appropriate, as soon as practicable and, in any case, before the First Horse Inspection.

#### **1.2. First Horse Inspection**

This takes place before the Dressage Test, normally the day before. It is conducted by the Ground Jury and the Veterinary Delegate acting together as a committee with the President of the Ground Jury in charge. The Horses must be inspected in hand, at rest and in movement on a firm level, clean but not slippery surface. The committee has the right and the duty to eliminate from the

competition any Horse that they judge is unfit, whether on account of lameness, lack of condition or for any other reason. In a doubtful case the Ground Jury may direct that the Horse be put in an officially supervised holding area for examination by the Associate Veterinarian. He will report any findings to the Ground Jury and the Veterinary Delegate, prior to the Horse being re-inspected by the committee, should the Athlete decide to represent the Horse. Horses in the holding area will be under the supervision and control of the Associate Veterinarian. In the event of equality of votes within the committee, the President of the Ground Jury will have a second and casting vote, and the decision will be announced immediately.

### 1.3. **Examination after Cross Country Obstacle Test**

This takes place after the Athlete has finished the Cross Country. It is conducted by a qualified veterinarian appointed by the Organising Committee in agreement with the Veterinary Delegate. In addition to carrying out any immediate treatment required by an injured or exhausted Horse, this veterinarian will decide if each Horse:

- is fit to return immediately on foot to its own stable,
- should remain for further treatment before returning to its stable,
- should be transported by vehicle (which must be available) either direct to its stable or to a veterinary hospital. This veterinarian has no authority to eliminate any Horse from the competition, but must report any doubtful case to the Ground Jury and to the Veterinary Delegate.

### 1.4. **Second Horse Inspection**

This takes place before the Jumping Test. It is conducted by the same committee and under the same conditions as the First Horse Inspection.

### 1.5. **Appeal**

At the three inspections where a Horse may be eliminated from the competition, there can be no appeal against the decision of the committee concerned. However, if requested, the president must give a reason for the committee's decision after the completion of the whole inspection. The Veterinary Delegate will be a member of the committee present at these three Horse inspections.

### 1.6. **During the Competition**

At any other time during the competition, any individual member of the Ground Jury has the right and the duty to eliminate any Horse, which in his opinion is lame or unfit to continue.

### 1.7. **Public**

The Horse Inspections shall be open to viewing by the public.

## 2. **One Day Events run over One or more days.**

### 2.1 **There will be no Horse Inspection.**

At any time during the competition any individual member of the Ground Jury has the right and duty to eliminate any Horse which in his opinion is lame or unfit to continue.

\* refer to NZPCA Annex 5 \*

## **Article 637 – MINIMUM STANDARDS FOR VETERINARY SERVICES AT EVENTS**

### **1. ONE DAY EVENTS**

- 1.1 New Zealand Championship: The Official veterinarian must be present throughout the event.
- 1.2 All other Events: Dressage Test - The Official Veterinarian does not have to be present for the Dressage Test but must be available within thirty minutes of being called.
- 1.3 Jumping and Cross Country Tests - The Official Veterinarian must be present for these Tests.

### **2. THREE DAY EVENTS**

- 2.1 New Zealand Championships - The Official Veterinarian must be present throughout the event.
- 2.2 All other Three Day Events:
  - 2.2.1 Dressage Test: The Official Veterinarian does not have to be present for the Dressage Test but must be available within thirty minutes of being called.
  - 2.2.2 Cross Country Test: The Official Veterinarian, and his assistant, together with another Veterinarian, who is not otherwise involved in inspection procedures and who will provide general Veterinary Services must be present.
  - 2.2.3 Jumping Test: The Official Veterinarian must be present.

3. THE ORGANISER should establish a centrally sited Veterinary Station at all events.

4. The following must be provided by Organisers at all events:

- 4.1 An effective method of communications for all Veterinarians on duty:
- 4.2 A four-wheel drive vehicle to facilitate access to every part of the course:
- 4.3 Equipment and supplies to deal with all emergencies, including euthanasia:
- 4.4 Screens for erecting around injured Horses (to shield from the public):
- 4.5 A low-loading transporter for removing dead or seriously injured Horses from the course or the arena and sufficient personnel familiar with the procedures of such removals.

\* refer to NZPCA Annex 5 \*

## **Article 638 – DESTRUCTION OF SEVERELY INJURED HORSES**

1. If a Horse is so severely injured that on humanitarian grounds it ought to be destroyed, the following procedure will apply:
  - 1.1 If the owner or his authorised representative is present his agreement will first be obtained by the Official Veterinarian or in his absence a veterinarian.
  - 1.2 If the owner or his representative is not available, the President of the Ground Jury or the Technical Delegate, acting on the advice of the Official Veterinarian or in his absence a veterinarian, may order the destruction of the Horse.
  - 1.3 If a veterinarian is unavailable, then the President of the Ground Jury or the Technical Delegate may order the destruction of the Horse.
2. The method of destruction shall be at the absolute discretion of the veterinarian or in the absence of a veterinarian, the President of the Ground Jury or the Technical Delegate.

## **Article 639 – DANGEROUS RIDING (525)**

1. Any Athlete who, at any time during the Competition deliberately or unintentionally by incompetence is exposing himself, his Horse or any third party to a higher risk than what is strictly inherent to the nature of the Competition will be considered to have acted dangerously and will be penalised accordingly to the severity of the infringement. Such acts may include without limitation any of the following:
  - a) Riding out of control (Horse clearly not responding to the Athletes restraining or driving aids).
  - b) Riding fences too fast or too slow.
  - c) Repeatedly standing off fences too far (pushing the Horse to the foot of the fence, firing the Horse to the fence).
  - d) Repeatedly being ahead or behind the Horse movement when jumping.
  - e) Series of dangerous jumps.
  - f) Severe lack of responsiveness from the Horse or the Athlete.
  - g) Continuing after three clear refusals a fall or any form of elimination.
  - h) Endangering the public in any way (e.g. jumping out of the roped track).
  - i) Jumping obstacles not part of the course.
  - j) Wilful obstruction of an overtaking Athlete and/or not following the instructions of the Officials causing danger to another Athlete.

Any individual member of the Ground Jury and the Technical Delegate has the right and the duty to monitor possible cases of dangerous riding and, if appropriate and practical, to stop and eliminate an Athlete on the Cross Country course for dangerous

riding. If not directly witnessed by the Ground Jury, the incident must be reported as soon as possible to the Ground Jury who will decide if and how to penalise the Athlete. The President of the Ground Jury can in addition designate one or more assistants (e.g. experienced Eventing Officials who are not in an Official function at the Competition, experienced Athletes or/and trainers not directly involved in the Competition) to help to monitor possible cases of dangerous riding in the Cross Country. The President of the Ground Jury will decide their specific role, authority and reporting procedure. It is recommended that these additional Officials be grouped in pairs on the Cross Country course.

2. Warnings and Penalties.

Different cases of dangerous riding will be dealt with one of the following provisions:

- a) Recorded Verbal Warning.
- b) Official Warning.
- c) 25 penalties.
- d) 25 penalties + Official Warning.
- e) Elimination.
- f) Elimination + Official Warning.

25 penalties will count as Cross Country obstacles penalties in the results.

Any of the above sanctions applied must always be reported by the Technical Delegate to be added on the Athlete sanction list.

3. Elimination Before Cross Country.

As a preventive risk management measure, the Ground Jury, at any time throughout the Competition, has the right and the duty to eliminate an Athlete to prevent him from starting the Cross Country Test, if there is a serious concern regarding his ability to control the Horse in that test.

Any such elimination must be associated with an recorded verbal warning or Official Warning.

Athletes who are eliminated in one test of the competition can not ride in subsequent tests unless approval has been given by the Technical Delegate in conjunction with the Ground Jury and the Organising Committee.

\* refer to NZPCA Annex 5 \*

## **Article 640 – ABUSE OF HORSE (526)**

1. Definition

Abuse of Horse means an action or omission which causes or is likely to cause pain or unnecessary discomfort to a Horse included but not limited to:

- a) Rapping.
- b) Riding an exhausted Horse.
- c) Excessive pressing of a tired Horse.
- d) Riding an obviously lame Horse.
- e) Excessive use of whip, bit and/or spurs.
- f) Horses bleeding on the flank(s) or back indicating excessive use of the whip and/or spurs.

If not directly witnessed by the Ground Jury, the incident must be reported as soon as possible to the Ground Jury through the Secretary of the Organising Committee or Cross Country Control Centre as appropriate. Where possible the report should be supported by a statement from one or more witnesses.

## 2. Warnings and Penalties

Any act or series of actions that in the opinion of the Ground Jury can be defined as abuse of Horse will be dealt with one or more of the following provisions:

- a) Recorded Verbal Warning.
- b) Official Warning.
- c) Elimination.
- d) Fine.
- e) Disqualification.

## 3. Use of the Whip

Excessive and/or misuse of the whip maybe considered abuse of Horse and will be reviewed case by case by the Ground Jury according to the following principles:

- a) The whip is not to be used to vent an Athlete's temper.
- b) The whip is not to be used after elimination.
- c) The whip is not to be used after a Horse has jumped the last fence on a course.
- d) The whip is not to be used overhand, (i.e. a whip in the right hand being used on the left flank).
- e) The whip is not to be used on a Horse head.
- f) The whip is not to be used more than three times for any one incident.
- g) If a Horse skin is broken the use of the whip is always excessive.

## 4. Blood on Horses

Blood on Horses may be an indication of abuse of Horse and must be reviewed case by case by the Ground Jury.

In minor cases of blood in the mouth, such as where a Horse appears to have bitten its tongue or lip, or minor bleeding on limbs, after investigation the Ground Jury may authorise the Athlete to continue.

\* refer to NZPCA Annex 5 \*

# **CHAPTER VIII**

## **GENERAL COMPETITION RULES**

### **Article 641 – CLASSIFICATION (528)**

#### **1. Classification in the Three Tests**

- 1.1. In the Dressage Test, each Athlete's good marks awarded by the judges are converted into penalty points. They are recorded for inclusion in the final classification and published.
- 1.2. In the Cross Country Test, each Athlete's penalties for faults at obstacles are added to the penalties that he may have incurred for excess time on Cross Country. They are recorded for inclusion in the final classification and published.
- 1.3. In the Jumping Test, each Athlete's penalties for faults at obstacles are added to the penalties that he may have incurred for excess time. They are recorded for inclusion in the final classification and published.

#### **2. Individual Final Classification**

- 2.1. The winning individual is the Athlete with the lowest total of penalty points, after adding together, for each Athlete, the penalty points incurred.
- 2.2. The best Cross Country score including faults at obstacles and time penalties.
- 2.3. If there is still equality, the classification is decided in favour of the Athlete whose Cross Country time was closest to the optimum time.
- 2.4. If there is still equality, the Athlete with the best Jumping score (time & obstacles).
- 2.5. If there is still equality, the Athlete with the best time (fastest) in the Jumping Test.
- 2.6. If there is still equality, the classification will be decided in favour of the Athlete with the best total of the Collective Marks in the Dressage Test.
- 2.7. If there is still equality the tie will remain in the Final Classification.

#### **3. Team Final Classification**

- 3.1. The winning team is that with the lowest total of penalty points, after adding together the final scores of the three highest placed Athletes in the team. For the purposes of Team Classification only, an Athlete who fails for any reason to complete the entire competition will be awarded 1000 penalty points.
- 3.2. In the event of equality between any two or more teams, the classification will be decided by the best combined highest three placings - e.g. a team with Athletes ranked individually 2nd, 8th and 12th, team total 22, will beat one with Athletes ranked 1st, 7th and



- 15th, team total 23. Should these figures be equal, a tie shall be declared.
4. Disqualification or elimination from one of the tests entails disqualification or elimination from the final classification.
  5. Disqualification due to positive Prohibited Substances test an Athlete or Horse.
    - 5.1. Official Team Competition:  
Should an Athlete and/or Horse be disqualified for positive Prohibited Substances test, the Athlete's result will be annulled. The team's result will be recalculated not taking into account the results achieved by the disqualified Athlete/Horse.
      - 5.1.1. If by removing the disqualified member from the team, the number of the team members is still within the minimum required number of three Athletes/Horses per team; the team will be considered eligible and be classified accordingly.
      - 5.1.2. If by removing the disqualified member from the team results, the number of the team members falls under the minimum required number (less than three Athletes/Horses per team), the team shall be disqualified. The classification of the other teams will be amended accordingly and prizes / (medals if applicable) redistributed.
    - 5.2. Individual Classification:  
If an Athlete and/or Horse is disqualified in the Individual event due to a positive Prohibited Substances test, the Athlete's results will be annulled and the next placed Athlete will move up accordingly and prizes (medals if applicable) redistributed.  
All ties will be broken according to paragraph 2 above.

#### **Article 642 – DISQUALIFICATION (528)**

1. Disqualification means that an athlete and his Horse or Horses may not take further part in the competition.
2. The Ground Jury may disqualify an athlete in addition to the following cases:
  - 2.1 Abuse of a Horse and/or dangerous riding. Article 639/640.
  - 2.2 Disobeying a condition of entry/condition of use of grounds imposed by a landowner on whose land an event is held.

#### **Article 643 – ENTRIES**

1. A Horse may be entered in any class for which is eligible in accordance with Article 613, but it may only compete in one.
2. Each entry form must be signed by the owner or owners or a person authorized by the owner or owners to make the entry. If any entry is made by other than the owner or owners of the Horse then the Horse will not be allowed to start in the event unless prior to the

commencement of the event, the written authority of the owner or owners is produced, if requested by the Organiser.

3. Every Athlete under the age of eighteen years must state his date of birth on the entry form when entering a competition and shall provide proof of his age if requested by the Organiser.
4. A Horse may be entered for class at CNC105 level or above only under its registered name and its registration number (supplied on registration) must be included on each entry form.
5. Incomplete entry forms will be considered invalid and will be returned to the person making the entry.
6. An entry received after the closing date of entries may be refused.
7. It is permissible for an Event to hold a waiting list provided the intention to do so is published in the schedule.

#### **Article 644 – DOUBLE ENTRY**

Except where stated to the contrary in the schedule, Athletes may make a double entry in a class where only one Horse is to compete. In such a case a non-refundable entry fee of \$10.00 is charged for the second Horse. The Event Secretary must be notified of the Horse to be withdrawn prior to the start of the event.

#### **Article 645 – EXCESSIVE ENTRIES AND BALLOTING**

1. When entries for a New Zealand Championship Competition are excessive then priority for acceptance will be as follows:
  - 1.1 FIRST: To members of a selected inter-island or national team to compete in a team competition run in connection with that New Zealand Championship Competition.
  - 1.2 SECONDLY: To those Horses having the better performance record in competitions in the level entered since the closing date of entries of the previous championship competition.
  - 1.3 THIRDLY: If the number of Horses of equal past performance exceeds the number of Horses that can be accepted, those Horses having the better performance record since 1st January of the previous year, will have priority. If the last qualified Horses are unable to be separated on past performance then they will be selected by ballot.
2. Other Competitions with unrestricted entries.

In all competitions other than New Zealand Championship competitions where the number of entries is unrestricted and the number of entries received is excessive, classes may be divided into divisions. Where a class is divided into divisions, entries for each division must be selected by ballot.

## **Article 646 – WITHDRAWALS AND SUBSTITUTIONS (530)**

1. Notifications of withdrawal from an event must be given to the Event Secretary prior to the commencement of the event. If a Horse is withdrawn prior to the closing date for entries, the entry fee will be refunded in full.  
There will be no refund for a withdrawal made within 48 hours of the commencement of the event except in exceptional circumstances at the discretion of the Organising Committee.
- 1.1 ONE DAY EVENTS - If the withdrawal is made in writing after the closing date for entries and more than 48 hours before the commencement of the event, the entry fee will be refunded less 20% without a Veterinary or Medical Certificate being required.
- 1.2 THREE DAY EVENTS - If the withdrawal is made in writing after the closing date for entries and more than 48 hours before the commencement of the event, the entry fee will be refunded less 20% only upon the production of a Veterinary or Medical Certificate.
2. Horses may be substituted by the owner or owners of the original Horse or his/their authorised agent up to the closing date for entries provided that the Organiser is informed in writing. No substitution may be made after the closing date of entries.
3. Athletes may be substituted by the owner of the Horse up to one hour before the first Athlete is scheduled to commence his Dressage Test provided that the Event Secretary is informed.
4. Athletes who do not declare their intentions to withdraw or infringe the substitution rules are liable to a penalty not exceeding \$100.00.

## **Article 647 – STARTING (533)**

1. **Draw**
- 1.1 The order of starting will be drawn by the Organiser after the closing date for entries.
- 1.2 Athletes riding more than one Horse when one is a member of a team shall always ride their team Horse first. Their second Horse will be placed in the last block of individuals. Athletes riding more than one Horse when both are eligible only for individual competition shall have the starting order of their two Horses determined by draw. They will always be placed at the beginning and end of the time schedule.
- 1.3 More than one member of a team will be permitted to ride two Horses only if there are enough Athletes in the competition to allow both Horses to be fitted into the time schedule.
- 1.4 Athletes with long distances to travel may be seeded at the discretion of the Organiser.

- 1.5 The method of draw must be approved by the Technical Delegate.
2. **Starting Order**
- 2.1 The Organiser may arrange for Horses in the final Test of a One Day Event to compete in reverse order of classification otherwise the order for starting at a One Day Event will be adhered to throughout the competition.
3. **Starting Times**
- 3.1 **ONE DAY EVENTS (CNC)**
- 3.1.1 The order of starting and earliest times at which Athletes will be required to start should be available to Athletes at least twenty-four hours prior to the start of the competition. Athletes must be prepared to start at their start time under penalty of elimination.
- 3.1.2 If in exceptional circumstances it is necessary to alter the timetable, all reasonable steps must be taken to inform Athletes when they must, under penalty of elimination, be prepared to start at their revised times.
- 3.1.3 Any Athletes who is ready may be started earlier at the discretion of the Ground Jury/Starter/Organiser.
- 3.2 **THREE DAY EVENTS (CCN)**
- 3.2.1 A timetable showing each Athlete's starting time for the Dressage Test and of the Cross Country Test shall be prepared in advance, based upon the length of the Dressage Test and the optimum time for the Cross Country Test. The interval between the starting times will be at the discretion of the Organiser with the approval of the Technical Delegate, but the interval must be sufficient to ensure that Athletes do not hinder each other. A copy of the timetable shall be made available to each Athlete as soon as practicable on the day before the start of each Test.

#### **Article 648 – TIMETABLE (534)**

1. The Dressage Test will always be held first.
2. The order of the Cross Country and Jumping Tests in a One Day Event is optional but must be clearly stated in the schedule.
3. Where two or more of the Tests take place on the same day, each Horse must be allowed a minimum of 30 minutes between Tests. If the Cross Country takes place before the Jumping Test, there must be an interval of at least 45 minutes between the finish of the Cross Country and the start of the Jumping Test for each Horse.
4. In exceptional circumstances, the Technical Delegate may authorise a reasonable reduction in these minimum intervals.

## **Article 649 – INDIVIDUAL AND TEAM COMPETITION**

### **1. Individual Competition**

There will always be an individual competition. Where there is a team competition each member of a team will be considered as an individual Athlete.

### **2. Composition of Teams**

Teams will consist of a maximum of four Athletes of which the three best scores will be considered for the final team classification. A team of three Athletes is permitted in which case scores of all three are taken into account for the final classification.

## **Article 650 – ORDERS**

Athletes and owners of competing Horses and their assistants must, under penalty or elimination, obey any order or direction given to them by an Official and they must, in particular, be careful not to do anything liable to upset or hinder the undisturbed progress of the competition.

## **Article 651 – NUMBERS (535.1)**

1. While competing, Athletes must wear their draw number both on their front and on their back during the Cross Country Test. The same numbers or armbands or bridle numbers must be used for the Dressage and Jumping Tests.
2. Athletes must ensure that back numbers are not obscured by hair.
3. At all times during an event when a Horse is out of the event stables, it is compulsory for the draw number or a substitute number provided by the Organiser to be worn by the Horse or Athlete/handler for the purposes of identification.
4. A fine not exceeding \$100.00 may be imposed for contravention of this rule.

\* refer to NZPCA Annex 5 \*

## **Article 652 – EXERCISING AND WARMING UP (535.2)**

### **2. Restrictions on Schooling Horses**

- 2.1. During the three days before the start of the First Horse Inspection or the Dressage Test as applicable and for the entire duration of an International Event, it is forbidden under penalty of disqualification for anyone to school a Horse other than the Athlete who will ride the Horse in the competition.
- 2.2. A groom, while mounted, is not permitted to school the Horse but only to hack it, exercise it or ride from one place to another. A groom may also work the Horse in hand or on the lunge.

2.3. Under penalty of disqualification, riding close to Cross Country obstacles, or riding in the Dressage or Jumping arenas prior to the actual competition is forbidden, unless specifically authorised by the Ground Jury or the Technical Delegate.

3. **Exercise Areas**

At International Events, appropriate areas suitable for the general exercise of Horses must be made available and must be open throughout the hours of daylight. These should include tracks and areas for hacking and for galloping. The Organising Committee must inform Athletes of the areas that are available for this purpose. Horses may be exercised only in such designated areas and/or in the practice areas for Dressage and Jumping.

4. **Practice Dressage Arena for Three Day Events.**

At least one practice arena of 60 by 20 metres must be put at the disposal of the Athletes two days before the first day of the Dressage Test. If possible, this arena should be of the same consistency as the competition arena.

5. **Practice Obstacles**

The only practice obstacles that Athletes may jump are those provided by the Organising Committee. The Organising Committee must provide at least two fixed practice obstacles which must be marked with red and white flags, of which the dimensions may not exceed those of the Cross Country Test.

Jumping Test: All obstacles must be marked with red and white flags. No part of the obstacle may ever be held by anyone. These obstacles may not be raised more than 10 cm above the height allowed in the Jumping Test. The spread may never exceed the maximum permitted. The practice obstacles shall only be jumped at times laid down by the Organising Committee. Violation of any of the above provisions relating to practice obstacles is forbidden, under penalty of disqualification (see "FEI Rules for Jumping").

6. **Stewards**

One or more Stewards must be appointed to ensure that the rules regarding exercising and warming-up are obeyed. A Steward must be present at whatever times the Organising Committee has laid down that practice obstacles may be used. Other practice and exercise areas may be patrolled by Stewards in a random manner.

## **Article 653 – ACCESS TO COURSES & ARENAS (536)**

1. **Dressage Arena**

2. Unless permission is given by the Jury, it is forbidden for Athletes, under penalty of disqualification, to enter the arena mounted at any time other than when performing their test during the competition.

The arena may be inspected on foot prior to the start or during breaks in the competition.

### **3. Cross Country Courses**

- 3.1. It is forbidden, under penalty of disqualification, to inspect the obstacles or the courses before they are officially open to the Athletes.
- 3.2. The course of the Cross Country Test will be opened to all Athletes for inspection 24 hours before the start of the Test, unless a shorter time is published in the Schedule.
- 3.3. All obstacles, flags and markers that have to be observed by Athletes shall be exactly in position when the course is opened to Athletes. Thereafter, they may not be moved or altered by Athletes under penalty of disqualification.
- 3.4. After the courses have been officially opened Athletes are allowed to revisit the courses during the hours of daylight and examine the obstacles. This examination must take place on foot only, unless special permission is given by the Jury.
- 3.5. It is forbidden under penalty of disqualification for Athletes to ride on, over or near any part of the Cross Country course within four weeks of the date of an Event. They may be waived if two or more Events are run in one season on the same grounds and it is not feasible to separate the dates by four weeks or more.

### **4. Jumping Course**

- 4.1. The course for the Jumping Test will be open to Athletes not less than 30 minutes before the start of the Jumping Test.
- 4.2. Athletes on foot will be admitted to the arena before the Jumping Test. Permission to enter the arena will be given by the Ground Jury. An announcement must also be made over the public address system.
- 4.3. Unless permission is given by the Jury, it is forbidden for Athletes, under penalty of disqualification, to enter the arena on foot once the competition has started.

## **Article 654 – INTERRUPTIONS AND MODIFICATIONS (537)**

### **1. Interruptions**

The timetable may be interrupted due to dangerous conditions. If necessary, the start of any Test may be brought forward, postponed or cancelled. The decision to interrupt or cancel a Test will be made by the President of the Ground Jury after consultation with the Technical Delegate if possible. In the case of an interruption, the event will be resumed as soon as possible at the point of the interruption. Every affected Athlete must receive sufficient warning before the resumption of competition.

## 2. **Modifications**

After the course(s) have been officially shown to, or are open for inspection by Athletes, alterations may be made only when exceptional circumstances (such as heavy rain or hot weather) make obstacles or a Test unfair or dangerous. The decision will be made by the President of the Ground Jury after consultation with the Technical Delegate if possible. He is authorised to make any necessary changes to the Test. In such cases, every Athlete and any Chefs de'Equipe must be officially and personally informed of the alteration before the start of the the Test concerned. Where appropriate, an Official must also be stationed at the place where the alteration has been made in order to warn the Athletes.

## **Article 655 – DRESS (538)**

### 1. **Protective Headgear**

It is compulsory that all Athletes wear protective headgear that conforms with the current New Zealand/Australian (AS/NZ) 3838, European (EN) 1384, British (PAS) 015, North American (ASTM) F1163 standard and is secured by a retention harness.

Failure to wear such protective headgear where and when required after being notified to do so by an Official shall result in an Official Warning being issued to the Athlete unless exceptional circumstances apply.

Top Hats and Uniform Hats are permitted as an exception to this rule only for the Dressage Test in CNC/CCN 3\* classes. The final warm up is from the point of entering the practice arenas or warm up areas and not to or from the stabling area.

### 2. **Whips**

Training (Practice): A whip no longer than 120cm including lash may be carried when riding on the flat at any time. While jumping any obstacle before the Cross Country and/or Jumping Test, a whip, if carried, must not be weighted at the end or exceed 75cm (30 inches) in length.

Horse Inspection: Athlete may carry a whip if he wishes.

Dressage Test: Carrying a whip of any kind during the Dressage test is forbidden.

Cross Country and Jumping: If a whip is carried in the Cross Country and/or Jumping Test, it must not be weighted at the end or exceed 75 cm (30 inches).

### 3. **537.1.3 Spurs**

- a) General - Spurs are optional for all three Tests. Spurs capable of wounding a Horse are forbidden. Spurs must be of smooth material (metal or plastic). If there is a shank it must not be more than four



centimetres long (the overall shank must be measured from the boot to the end of the spur) and must point only towards the rear. The end of the shank must be blunt to prevent wounding a Horse. If the shank is curved, the spurs must be worn only with the shank directed downwards. Metal or plastic spurs with round hard plastic or metal knobs, "Impulse spurs" and "Dummy spurs" with no shank are allowed.

- b) Rowel Spurs - Spurs with rowels are allowed only for the Dressage and Jumping Tests and when practising/warming up for Dressage and Jumping. If they are used, rowels must be free to rotate and the rowel must be round and smooth (no tines allowed).

#### 4. **Boots**

In all Tests, boots (other than as part of regulation service dress) must be black, brown or black with a brown top. They must either be long boots in one piece or a full grain smooth leather leg piece and leather boot.

Jodphur Boots may be worn in CNC105 classes and below.

#### 5. **Dressage Test**

- 5.1. Civilian - compulsory except as indicated in 5.2 & 5.3 below: hunting dress or uniform of a riding club, white shirt and tie, gloves, white, fawn or cream breeches, boots, protective headgear and spurs (in accordance with Para. 3 above).
- 5.2. Classes below CNC 3\* Level at a One Day Event, Athletes if they wish may wear a tweed jacket with fawn or beige breeches and black or brown boots.
- 5.3. At CNC 1\* or below level, the wearing of a tailcoat is not encouraged.
- 5.4. Members of armed and police forces, members and employees of military establishments and national studs - compulsory: service dress and gloves, regulation headgear and spurs (in accordance with Para. 3 above).

#### 6. **Cross Country Test**

Light-weight clothing is appropriate for this test. Protective headgear, in accordance with Para. 1 above, and boots must be worn. Back protectors must be worn. Spurs are optional; if used, they must be in accordance with Para. 3 above.

##### **Inflatable / Air Jackets**

If an Athlete chooses to wear an airbag style body protector, it must be worn over a permitted body protector.

#### 7. **Jumping Test**

- 7.1. Civilian - hunting dress or uniform of a riding club, white shirt and tie, white, fawn or cream breeches, boots. Spurs are optional but, if used, must be in accordance with Para. 3 above.

- 7.2. Classes below CNC 3\* Level at a One Day Event, Athletes if they wish may wear a tweed jacket with fawn or beige breeches and black or brown boots.
- 7.3. Members of armed and police forces, members and employees of military establishments and national studs - service dress. Spurs are optional; if used they must be in accordance with Para. 3 above.
- 7.4. In each case, a protective headgear, in accordance with Para. 1 above, must be worn.

## 8. **Inspection of Dress**

A Steward can be appointed to inspect whips and spurs before any test. He has the authority to refuse permission for any Athlete to start, whose whip or spurs contravene this article. He will immediately report the circumstances to the Ground Jury for confirmation.

An Athlete who competes with illegal whip(s) or spurs will be eliminated. An Athlete who competes with incorrect items of dress is liable to elimination, at the discretion of the Ground Jury.

\* refer to NZPCA Annex 5 \*

## **Article 656 – SADDLERY (539)**

### 1. **Exercise Areas**

The following are compulsory: an English type saddle and any form of bridle, including double bridle, snaffle, gag or hackamores. Running martingales with stoppers (with snaffle only), Irish martingales, bit guards, boots, bandages, fly shields, nose covers and saddle covers are permitted. Single direct side reins are permitted only while lunging (only with one lunge line) as are running reins and chambons. Other martingales, any other kind of gadget (such as bearing, side or balancing reins, etc.) and any form of blinkers, are forbidden, under penalty of elimination.

### 2. **Dressage Test**

- 2.1. The following are compulsory: an English type saddle and a permitted bridle.
- 2.2. A double bridle with cavesson noseband i.e. bridoon and curb with curb chain (made of metal or leather) is permitted, as authorized by the Rules for Dressage. In the CNC 1\* level or below tests riding with a curb bit is not allowed.
- 2.3. A snaffle bridle of which the bit is made of metal, leather, rubber or plastic material is also permitted as authorized by the Rules for Dressage. It must be made entirely of leather, except for a small disc of sheepskin, which may be used in the intersection of the two leather straps of a crossed noseband. For drawings of permitted bits and nosebands, see Annex 1. Certain tests may specify that only a snaffle bridle is allowed.

2.4. Martingales, bit guards, any kind of gadgets (such as bearing, side, running or balancing reins, etc.), any kind of boots or bandages and any form of blinkers, earmuffs, earplugs, hoods and saddle covers, are under penalty of elimination, strictly forbidden in accordance with the Dressage rules. A breast plate may be used. Protective fly hoods are permitted for outdoor Events. However, these will be systematically checked by Stewards at the end of the test to ensure that nothing prohibited has been added to or is covered by the fly hoods. The fly hoods should be discreet and should not cover the Horses' eyes. False tails are permitted provided they are not weighted or otherwise "enhanced" in any way whatsoever. For National Classes only, nose nets may be used, but must be discreet and may not cover the mouth of the Horse.

### 3. **Cross Country Test & Jumping Test**

3.1. The type of saddlery is optional. Gags or "bitless bridles" are allowed as are unrestricted running martingales with stoppers or Irish martingales. Reins must be attached to the bit(s) or directly to the bridle. Sheepskin (or other material) may not be used as addition on cheek pieces of the bridle. The stirrup iron and stirrup leathers must hang free from the bar of the saddle and outside of the flap.

3.2. The following are forbidden: any form of blinkers, side, running or balancing reins; tongue straps and /or tying down the Horse's tongue; any other restrictions, any bit or other item of saddlery likely to wound a Horse.

3.3. **Boots:** For the Jumping Test, the total maximum weight of equipment allowed to be added to a Horse's leg, front or hind (single or multiple boots, fetlock rings etc.) is 500g (shoe excluded). Failure to comply with this paragraph will incur elimination.

### 4. **Inspection of Saddlery**

4.1. A Steward can be appointed to check the saddlery of each Horse before it enters the arena or starts a test.

4.2. In the Dressage Test, the checking of the bridle must be done with the greatest caution. If the Athlete so requests, the bridle and bit may be checked immediately after the test has been completed. However, should the bridle or bit in such a case be found not to be permitted, the Athlete shall be eliminated by the Ground Jury.

### 5. **Responsibility of Athletes**

It is the Athlete's responsibility to ensure that the saddlery complies with the provisions of this article. If an Athlete exercises with forbidden saddlery he will be disqualified. If an Athlete performs a Test with improper saddlery he will be eliminated.

\* refer to NZPCA Annex 5 \*

## **Article 657 – UNAUTHORISED ASSISTANCE (540)**

1. Any intervention by a third party, whether solicited or not, with the object of facilitating the task of the Athlete or of helping his Horse, is considered unauthorised assistance and the Athlete is liable to be eliminated.
2. In particular, the following are forbidden:
  - intentionally to take a lead from another Athlete;
  - to be followed, preceded or accompanied, on any part of the course, by any vehicle, bicycle, pedestrian, or Horseman not in the competition;
  - to post friends at certain points to call directions or make signals in passing;
  - to have someone at an obstacle to encourage the Horse by any means whatsoever;
  - to tamper with the obstacles or any part of the course, including, for instance, flags, indicators, markers, notices, ropes, trees, branches, wire or fences, whether temporary or permanent.
3. The use of any electronic receiving apparatus by Athletes is strictly forbidden, while mounted during competition.
4. Officials or spectators who draw the attention of an athlete to a deviation from the course are giving unauthorised assistance which may result in the elimination of the Athlete. In such a case, an official is liable to be disciplined according to the “General Regulations”.
5. Any case of unauthorised assistance will be decided by the Ground Jury.
6. **Exceptions**
- 6.1 After a fall or if an Athlete dismounts, he may be assisted to catch his Horse, to adjust his saddlery, to remount or be handed any part of his saddlery or equipment while he is dismounted or after he has remounted.
- 6.2 Whip, headgear or spectacles may be handed to an Athlete without dismounting.
- 6.3 An Athlete may receive clarification of jumping penalties from the Fence Judge, e.g. after having knocked a flag at the corner of obstacle.

# CHAPTER VIII

## DRESSAGE TEST

### **Article 658 – RULES FOR DRESSAGE TEST (542)**

The “FEI Rules for Dressage” apply for Eventing Dressage except where otherwise provided in these rules. Any modification introduced by the FEI Dressage Committee during the year will be evaluated for inclusion in these Rules for Eventing from 1st January the following year.

1. All Tests must be carried out entirely from memory, and all movements must follow in the order laid down in the Test.
2. The trots must be executed as specified in the Test.
3. The permitted bridles are specified in the Test.

### **Article 659 – TEST (542.1)**

The nature of the Dressage Test will be determined by the level of the Event and will, therefore, be related to the quality and the standard of preparation of the Athletes and Horses. Within the limits shown in Annex 2 for One Day Events and Annex 3 for Three Day Events, Organising Committees are free to select the specific test to be used.

### **Article 660 – JUDGES POSITION (542.3)**

The president (C) shall be on the prolongation of the centre line, the other judges will be positioned according to the chart below. The positions shall be determined by the Technical Delegate, taking into account the positions recommended for each test. Judges must have a good view of the arena. The judges placed along the short side, must be on the outside of and 5 metres from the arena.

Number of Judges	One Day Event (CNC)	Three Day Event (CCN)
3	C, H, B or C, M, E	C, H, B or C, M, E
2	C, B or C, E	C, B or C, E
1	C	n/a

## **Article 661 – SCORING (544)**

### **1. Marking**

- 1.1. Judges will award good marks from 0 to 10 for each numbered movement and for each of the collective marks. Note. From the 1st January 2015, half- marks will be implemented as per Dressage Rules.
- 1.2. Errors of course or test will be penalised as follows:

1st time	2 points
2nd time	4 points
3rd time	elimination
- 1.3. In the case of a fall of Horse and/or Athlete, the Athlete will not be eliminated.  
He will be penalised by the effect of the fall on the execution of the movement concerned and in the collective marks (No 3 and/or No 4).
- 1.4. After elimination (except when eliminated for marked lameness), an Athlete may continue his performance to the end. The marks will be awarded in the ordinary way.

### **2. Calculation of Scores**

- 2.1. The good marks from 0 to 10 awarded by each judge to an Athlete for each numbered movement of the Dressage Test together with the collective marks are added together deducting any error of course or test.
- 2.2. For each judge the percentage of maximum possible good marks obtainable is then calculated. (Percentage is obtained dividing total good marks of the judge (minus any error of course or test) by maximum possible good marks obtainable and then multiplying by 100 and rounding the result to two decimal digits. This value is shown as the individual mark for that judge.
- 2.3. Average percentage for the Athlete is obtained by adding together the percentage for each judge and dividing by the number of judges always rounding the result to two decimal digits.
- 2.4. In order to convert average percentage into penalty points, this must be subtracted from 100 and multiplied by 1.0, with the resulting figure being rounded to one decimal digit. The result is the score in penalty points for the test.

### **3. Additional errors of course**

All of the following are considered errors, and two (2) points will be deducted per error, but they are not cumulative and will not result in Elimination (including for Freestyle tests):

- Entering the space around the arena with whip;
- Entering the Dressage arena with whip;
- Entering the arena before the sound of the bell;

- Not entering the arena within forty five (45) seconds after the bell, but within ninety (90) seconds;
- 3.2. Exceeding 90 seconds – Elimination. A Horse and Athlete combination not entering the Competition arena within ninety (90) seconds after the bell will be Eliminated except where a valid reason thereto has been informed to the judge at C. ( A valid reason may be losing a shoe, and maybe if a horse stops to defecate or urinate.) In the event that the horse starts to defecate or urinate, the clock will be stopped until the horse is ready to continue at which point the clock will be restarted. ( see FEI Dressage Rules).

### **Article 662 – ARENA**

Arenas may be constructed from rope, plastic chain, plastic pipes, or in accordance with FEI Rules for Dressage. Arenas must be as safe as possible. If rope and steel pegs are used, the rope shall be kept taut but not wrapped around the pegs, approximately 30cm above the ground, and any sharp elements of pegs should be covered to protect Horses.

# CHAPTER IX

## CROSS COUNTRY TEST

### Article 663 – RULES GOVERNING THE CROSS COUNTRY TEST (544)

#### 1. Starting

- 1.1 Athletes at the start of the Cross Country must be under the control of a starter and may not deliberately start until instructed to do so, under penalty of elimination, at the discretion of the Ground Jury. The Horse does not have to stand absolutely immobile, but the Athlete must not get any advantage from a flying start. Each Athlete should be given reasonable warning before the time he is due to start, but it is the Athlete's responsibility to ensure that he is ready to start at the correct time.
- 1.2 In order to simplify the task of the starter, an enclosure approximately 5 X 5 m will be built at the start of Cross Country, with an open front through which Horses will start and a gap in one or both sides from which the Horses will enter. Each Athlete must start from within the enclosure and is at liberty to move around and through the enclosure as he pleases. An attendant may lead the Horse into the enclosure and may hold the Horse until the signal to start is given. From that instant, the Athlete is considered to be on the course and no further assistance may be given (see Art. 663.8).
- 1.3 If an Athlete starts early on the Cross Country, his time will be recorded from the moment he crossed the start line.
- 1.4 **Late for Start:**
  - 1.4.1 If for any reason an Athlete is not ready to start the Cross Country at his correct time, he may be allowed, at the discretion of the starter, to start when he is ready, subject to the following conditions:
    - A late Athlete will not be permitted to start if he is likely to interfere with the subsequent Athlete nor may he start after the subsequent Athlete.
    - His starting time will be recorded as if he had started at the correct time.

#### 2. Time

- 2.1 Optimum time: the distance chosen, carried out at the chosen speed, gives the optimum time. An Athlete exceeding the optimum time will be penalised in accordance with Art. 666.2 up to the time limit. The time limit is twice the optimum time.
- 2.2 Timing of the Cross Country Test: if an Athlete is stopped by an official, e.g. for a broken fence, accident, being overtaken, for medical or veterinary examination, etc., the time during which he is



prevented from continuing until he is cleared to start will be recorded and deducted from the total time taken to complete the test.

3. **Error of Course**

All compulsory passages on Cross Country and all obstacles, including all elements and/or options, must be passed or jumped in order under penalty of elimination. All red or white flags must be respected wherever they occur on all courses, except as provided in Art. 667.5, under penalty of elimination, at the discretion of the Ground Jury. Retaking an obstacle already jumped is forbidden, under penalty of elimination, except as provided for in Art. 667.5.

4. **Pace & Dismounting**

Between the start and finish of the Cross Country, Athletes are free to choose their own pace. They must be mounted to pass all red and white boundary flags. Dismounting as a result of attempting an obstacle, whether voluntary or not, is penalised in accordance with Art. 667. Elsewhere on the courses, Athletes may dismount without incurring a fault other than possible penalties for exceeding the optimum time.

5. **Overtaking**

5.1 Any Athlete who is about to be overtaken by a following Athlete must quickly clear the way. Any Athlete overtaking another Athlete must do so only at a safe and suitable place.

5.2 When the leading Athlete is before an obstacle and about to be overtaken, he must follow the directions of the officials. When the leading Athlete is committed to jumping an obstacle, the following Athlete may jump that obstacle only in such a way that will cause no inconvenience or danger for either.

5.3 The penalty for wilful obstruction of an overtaking Athlete, failure to follow the instructions of the officials, or causing danger to another Athlete is elimination at the discretion of the Ground Jury.

5.4 The time during which the Athlete is held up by officials will be recorded and deducted from the total time taken by the Athlete to complete the course.

6. **Athletes in Difficulty**

6.1 If, in attempting to negotiate an obstacle, a Horse should be trapped in such a way that it is unable to proceed without assistance or is liable to injure itself, the Athlete will be instructed by the fence judge to dismount and will be eliminated.

6.2 The fence judge will decide if parts of it need to be dismantled or if any other assistance needs to be given to extricate the Horse.

7. **Stopping Athletes**

7.1 If any part of an obstacle is obstructed by an Athlete in difficulty, or if any obstacle has been dismantled to release a fallen Horse, or if an

obstacle has been broken and is not yet rebuilt, or in any other similar circumstances, subsequent Athletes must be halted.

- 7.2 In such a case, an official should be posted in the path of an oncoming Athlete. He shall wave a red flag, which indicates that the Athlete must stop. Failure to stop is penalised by elimination at the discretion of the Ground Jury.
- 7.3 Athletes may be stopped at obstacles or at Stopping Points on the course.
- 7.4 The official will stop Athletes only upon the instruction of the Control Centre or during an emergency at his own obstacle.
- 7.5 The time during which the Athlete was stopped, from the moment he passed the Stopping Point until he re-passed that same point after being given the order to restart, will be recorded. It will be deducted from the total time taken by the Athlete to complete the course. It is clearly intended that the time shall be taken as the Athlete gallops past the Stopping Point, not after he halts nor after a start from the halt.

## 8. **After Elimination**

An Athlete eliminated for any reason must leave the course at once and has no right to continue. The Athlete must walk his Horse off the course, either mounted or dismounted. Violators shall be warned or fined, at the discretion of the Ground Jury, in accordance with the “ESNZ General Regulations” & Article 639 of these Rules.

## **Article 664 – COURSES (546)**

### 1. **White Boundary Flags**

Red or white boundary flags shall be used to mark the starting and finishing lines, to mark compulsory passages, and to define obstacles. They are placed in such a way that an Athlete must leave a red flag on his right and a white flag on his left.

### 1.2 **Yellow Directional Markers**

Yellow directional markers shall be used to show the general direction to be taken and to help the Athlete to find his way.

### 1.3 **Numbers & Letters**

Each obstacle on Cross Country shall be numbered. Obstacles with elements or options (see Art. 665.2) shall, in addition, be lettered (A, B, C, etc.). Each compulsory passage shall be marked and numbered consecutively.

### 1.4 **Start & Finish Signs**

In addition to the red or white boundary flags, the starting and finishing line shall be marked by distinct signs.

## **2. Distances & Speeds**

2.1 The distances and the speeds demanded are determined by the intended difficulty of the whole test. Within the limits shown in Annex 2 and Annex 3, Course Designers may, with the approval of the Technical Delegate, choose the distances most suitable to the terrain and to the quality and standard of preparation of the Athletes.

2.2 Any modification to the distances and speeds specified in Annex 2 and Annex 3 must be approved by the Chairman of ESNZ Eventing and by the Chairman of the ESNZ Eventing Technical Committee, except as provided for in Article 654.2.

## **3. Finishing Lines**

The last obstacle of the Cross Country shall be not less than 20 metres and no more than 50 metres from the finishing line.

## **4. Course Plans**

### **4.1 ONE DAY EVENTS**

4.1.1 A plan of the Cross Country course at a One Day Event must be displayed by the time the course is open for inspection by Athletes and must include the positions of the start and finish; the numbered obstacles and compulsory passages; the distance; the optimum time and time limit and where possible any decisions made by the Ground Jury in regard to the course.

### **4.2 THREE DAY EVENTS**

Each Athlete will be given in advance a plan showing the track of the courses.

4.3 The plan must include the following: the positions of the starts and finish; the numbered obstacles and compulsory passages; the distance; the optimum times and time limit.

## **Article 665 – OBSTACLES (547)**

### **1. Definition**

An obstacle is considered as such if and only if its extremities are marked with a red and white flag or flags and it is numbered and/or lettered accordingly. All significant jumping efforts that the average Horse may be expected to attempt to negotiate must be defined as an obstacle or element and flagged, numbered and/or lettered accordingly.

### **2. Type of Obstacles**

#### **2.1 General**

The obstacles must be fixed and imposing in shape and appearance. When natural obstacles are used, they should, if necessary, be reinforced so that they remain in the same state throughout the test. All reasonable precautions must be taken to prevent the possibility of an Athlete being able to pass mounted under an obstacle. Portable

fences must be secured to the ground in a way that they have no possibility to move if hit by a Horse.

## 2.2 Construction

The obstacles at which a Horse, in falling, is likely to be trapped or to injure itself, must be built in such a way that part of the obstacle can be quickly dismantled and can be quickly rebuilt exactly as before. Such a construction must not in any way detract from the solidity of the obstacle.

## 2.3 Brush

Brush on top of fences must be made of flexible and deformable material. The fence must be constructed so that a Horse clearing the fixed and solid part is unlikely to be injured by the brush or hedge. Bullfinches, i.e. thin brushes or hedges through which a Horse can be expected to jump are permitted, provided they can be maintained in consistent condition throughout the test.

## 2.4 Frangible/Deformable Obstacles

Obstacles can be provided with frangible/deformable technology only if such technology has been approved by the FEI according to the FEI Standard for the minimum strength of frangible/deformable Cross Country fences. A list of approved technologies is published on the FEI website.

## 2.5 Water Crossings

In all water crossings the bottom should be firm and consistent.

## 3. Dimensions

The dimensions of obstacles must be within the limits shown in the Table of Obstacle Heights and Spreads for the relevant level of Competition see Annex 2 and Annex 3 table Dimensions.

### 3.1 Fixed Part

The fixed and solid part of an obstacle may not exceed the specified height or spread at any of the points at which an Athlete might reasonably attempt to negotiate the obstacle.

### 3.2 Brush

The overall height and the height of the solid part of a hedge or brush fence must never exceed the relative dimension set in the Table of Obstacle Heights and Spreads for the relevant level of Competition see Annex 2 and Annex 3 table Dimensions.

### 3.3 Water

At obstacles involving water crossings (ford, lake or wide river), the depth of water, from the entrance to the exit must not exceed 35 centimetres. The length of any water crossing must be at least six meters between entry and exit, except where an exit step(s) or fence is jumped directly out of the water, in which case the minimum length must be nine meters.

### 3.4 Obstacles with Spread Only

At an obstacle with spread only (dry or water filled ditch), a guard rail or hedge in front that facilitates jumping is permitted. It may not exceed 50 centimetres in height and must be included in the measurement of the spread.

### 3.5 Drops

At 1 star level, no drops over 160 centimetres are permitted. At 2 and 3 star level drops with a flat landing exceeding 160 centimetres are limited to two.

## 4. Measurement

### 4.1 Height

The height of an obstacle is measured from the point where the average Horse would take off.

### 4.2 Spread

The spread of an open obstacle (e.g. oxer or ditch) is measured from the outside of the rails or other material making up the obstacle. The spread of a closed obstacle with a solid top (e.g. Tables) is measured from the highest point to the highest point.

### 4.3 Drop

The drop on the landing side of an obstacle is measured from the highest part of the obstacle, including from the top of a brush fence, to the point where the average Horse would land.

### 4.4 Natural Obstacles

When the height of an obstacle cannot be clearly defined (e.g. natural hedge, bullfinch), the height is measured to the solid part of the obstacle through which a Horse cannot pass with impunity.

## 5. Obstacles with Elements and/or Options

### 5.1 Obstacles Composed of Several Elements

If two or more jumping efforts, sited closely together, are designed as one integral test, they will be designated as "elements" of a single numbered obstacle. Each element will be marked with a different letter (A, B, C, etc.) and must be negotiated in the correct order. Where two or more jumping efforts are sited so closely together that after a refusal or run out it would be unreasonably difficult to attempt to negotiate the second or subsequent effort without retaking one or more earlier efforts, these jumping efforts must be designated as one numbered obstacle and lettered accordingly.

### 5.2 Obstacles with Alternatives

Where an obstacle may be jumped in one effort but has alternatives involving two or more efforts, each of these alternatives must be lettered or numbered as an element.

### 5.3 Black Flagged Alternatives

Alternative obstacles or elements may be flagged separately and must be identified by the same number/letter as on the direct route. In this case only one obstacle/element has to be jumped, both sets of flags must be marked with a black line. An Athlete is permitted to change without penalty from one black flagged line to another (e.g. jumping 6a left hand route then 6b right hand route) provided he has not presented his Horse at the next element of the original line.

### 6. Number of Jumping Efforts

The total number of jumping efforts shall be within the limits (minimum and maximum) shown in Annex 2 and Annex 3 for the relevant level of Competition.

The efforts to be counted are the efforts on the route expected to be taken by the average Horse.

\* refer to NZPCA Annex 5 \*

## Article 666 – SCORING (548)

### 1. Faults at Obstacles

#### 1.1 Refusal, run-out or circles

##### **105 and below Classes**

First refusal, run-out or circle 20 penalties

Second refusal, run-out or circle at the same Obstacle 40 penalties

Third refusal, run-out or circle at the same Obstacle elimination

Fourth refusal, run-out or circle on XC Course elimination

##### **1\* and above Classes**

First refusal, run-out or circle 20 penalties

Second refusal, run-out or circle at the same Obstacle 40 penalties

Third refusal, run-out or circle on XC Course elimination

#### 1.2 Falls

Fall of Athlete on XC Course 65 penalties

Second fall of the Athlete on XC Course elimination

Fall of Horse anywhere on the course elimination

1.3 Breaking a frangible obstacle/device 21 penalties

1.4 Dangerous Riding 25 penalties

### 2. Time Faults

2.1 Exceeding Optimum Time:  
0.4 penalty per commenced second

2.2 Exceeding Time Limit: Elimination

### **3. Additional Reasons for Elimination**

3.2 Elimination must be applied in the following cases:

3.2.1 Abuse of Horse, Art. 640.

3.2.2 Competing with improper saddlery, Art. 656.3.

3.2.3 Error of course not rectified, Art. 663.3.

3.2.4 Omission of obstacle or compulsory passage, Art. 663.3.

3.2.5 Jumping or incurring a fault at an obstacle in the wrong order or passing through a compulsory passage in the wrong order, Art. 663.3.

3.2.6 Jumping an obstacle in the wrong direction, Art. 663.3.

3.2.7 Retaking an obstacle already jumped, Art. 663.3.

3.2.8 Athlete in difficulty Art. 663.6.1.

3.1 Elimination is left to the discretion of the Ground Jury in the following cases:

3.1.1 Deliberately starting before being given the signal to start, Art. 663.1.1.

3.1.2 Jumping or attempting to jump any obstacle without headgear, or with an unfastened retention harness, Art. 655.1.

3.1.3 Wilful obstruction of an overtaking Athlete, or failure to follow the instructions of the officials while being overtaken, Art. 663.5.3.

3.1.4 Causing danger to another Athlete while overtaking that Athlete, Art. 663.5.3.

3.1.5 Failure to stop when signalled, Art. 663.7.2.

3.1.6 Unauthorised assistance, Art. 663.8.1.

3.1.7 Passing through a compulsory passage in the wrong direction without correction, Art. 663.3.

3.1.8 Dangerous Riding, Art. 639.

\*refer to NZPCA Annex 5\*

### **Article 667 – DEFINITIONS OF FAULTS (549)**

The following faults at obstacles (refusal, run-out, circle or fall) will be penalised unless, in the opinion of the responsible official, they are clearly not connected with the negotiation or attempted negotiation of a numbered obstacle or element.

#### **1. Refusal**

At obstacles or elements with height (exceeding 30 cm), a Horse is considered to have refused if it stops in front of the obstacle to be jumped.

At all other obstacles (i.e. 30 cm or less in height) a stop followed immediately by a standing jump is not however penalised, but if the halt is sustained or in any way prolonged, this constitutes a refusal. The Horse may step sideways but if it steps back, this is a refusal.

After a refusal, if an Athlete redoubles or changes his efforts without success, or if the Horse is represented at the obstacle after stepping back and stops or steps back again, this is a second refusal; and so on.

## 2. **Run-out**

2.1 A Horse is considered to have run out if, having been presented at an element or obstacle on the course, it avoids it in such a way that the head and neck of the Horse and the head of the Athlete when mounted fail to pass between the extremities of the element or obstacle as flagged.

2.2 An Athlete will also be penalised 20 penalties if the Horse disobediently avoids that part of the fence at which it has been presented, but succeeds in negotiating the obstacle at some other part, between the flags. However an Athlete is permitted to change his mind as to where he jumps an obstacle or element at any time, without penalty, including as a result of a mistake at a previous obstacle or element. If, however, the Horse avoids part of the obstacle at which it has been presented, 20 penalties are incurred.

2.3 Judging of Bounce obstacles:

At any obstacle where the distance between elements is 5 metres or less (i.e. a 'bounce'), when a Horse has negotiated the first element without penalty, he will be deemed to have been presented at the second element – and similarly if the "bounce" is for example the second and third elements of a combination. Thus if an Athlete "changes his mind" while negotiating the first element of a "bounce" and , for example, then goes a longer route, he will still be penalised 20 penalties for a run-out.

## 3. **Circle**

3.1 Separately Numbered Obstacles

At separately numbered obstacles, an Athlete may circle between or around them without penalty provided he has not presented his Horse at the second or subsequent obstacles.

3.2 Obstacles Composed of Several Elements

At an obstacle composed of several elements (A, B, C, etc) a Horse will be penalised if it passes around any element or circles between elements.

3.3 After being penalised for a refusal, run-out or circle, an Athlete, in order to make another attempt, is permitted to circle one or more times without penalty, until he again presents his Horse at the obstacle.

At an obstacle composed of several elements if the Athlete refuses, runs out or circles at any element, he is permitted to retake any



elements already jumped, although he is liable to be penalised for any fault even if he has previously jumped an element successfully. If after a refusal, run-out or circle, he wishes to pass through flags in the wrong direction in order to retake an element, he may do so without penalty.

4. **Fall**

4.1 An Athlete is considered to have fallen when he is separated from his Horse in such a way as to necessitate remounting or vaulting into the saddle.

4.2 A Horse is considered to have fallen when at the same time both its shoulder and quarters have touched either the ground or the obstacle and the ground or when it is trapped in a fence in such a way that it is unable to proceed without assistance or is liable to injure itself.

5. **Instruction to Officials**

Where there is any doubt as to the correct interpretation of the rules of judging any element, obstacle or combination of obstacles, it is recommended that the Technical Delegate, in consultation with the Ground Jury if possible, should approve the instructions to the Officials, providing a rough sketch if necessary, and all Athletes will be informed at the briefing or as soon as possible after the Technical Delegate's decision, if later.

# CHAPTER X

## JUMPING TEST

### **Article 668 – RULES FOR JUMPING TEST (550)**

The “FEI Rules for Jumping” apply for Eventing Jumping except where otherwise provided in these rules. Any modification introduced by the FEI Jumping Committee during the year will be evaluated for inclusion in these Rules for Eventing from 1st January the following year.

### **Article 669 – OBJECT & GENERAL DESCRIPTION (551)**

1. This test is similar to an ordinary jumping competition, but without any attempt to find a ‘winner’ of this test on its own. Its main objective is to prove that, the Horse and Athlete are well trained in the specialist discipline of jumping.
2. The nature of the course, its length, the speed demanded and the dimensions of the obstacles depend on the degree of difficulty of the whole competition.

### **Article 670 – SIZE OF ARENA**

As an exception to FEI Rules for Jumping, any arena of less than 3,000 sq m and/or less than 50m wide on the short side must be specifically notified to ESNZ Eventing and approved by the Technical Delegate before the schedule for the event is approved.

If the arena is less than 5000 square metres the maximum speed for 3\* shall be 350mpm.

In arenas less than 2300sq m the maximum speed for 1\* and 2\* will be 325 mpm.

### **Article 671 – COURSE - OBSTACLES (552)**

#### **1. Distance & Speed**

Within the limits shown in Annex 2 and Annex 3, the Course Designer is free to plan a track suitable to the level of the competition. In exceptional circumstances it is permissible, with the approval of the Technical Delegate and Ground Jury to add up to 10% of the maximum permitted distance.

#### **2. General**

The obstacles will be standard Jumping obstacles, with the limits as shown in Annex 2 and Annex 3.

#### **3. Dimensions**

The dimensions of the obstacles shall not exceed the limits shown in Annex 2 and Annex 3. At least two thirds shall be of maximum height

for the level offered, the only exception to this being the CNC1\* class where up to three obstacles only shall be at the maximum height. The top spread of an obstacle may not be more than 30 cm wider than the height of the obstacle (i.e. Obstacle height 120 cm, maximum spread 150 cm). A tolerance of 5 cm in height is acceptable, if dictated by the terrain or by the spacing of the cups as authorised by the FEI Jumping Rules.

#### 4. **Type of Obstacles**

The obstacles should have a balance of vertical and spread obstacles.

Closed combinations are not permitted. A water jump is not permitted, but a water ditch with rails over is allowed. ESNZ approved safety cups are mandatory as support for back poles of spread obstacles. Alternative obstacles are permitted. These jumps are to be marked on the course plan with the same number and with the word "Alternative".

### **Article 672 – SCORING (553)**

#### 1. **Faults on the Course**

Knocking down an obstacle	4 penalties
First run-out, refusal or unauthorised circle in the whole test	4 penalties
Second run-out, refusal or unauthorised circle in the whole test (105 and Below)	8 penalties
Second run-out, refusal or unauthorised circle in the whole test (1* and Above)	elimination
Third run-out, refusal or unauthorised circle in the whole test (105 and Below)	elimination
First fall of Athlete	8 penalties
Second fall of Athlete	elimination
First fall of Horse	elimination

#### 2. **Time Faults**

The length of the course and the speed demanded determine the time allowed. Completing the course in less than the time allowed is not rewarded, but exceeding the time allowed is penalised by one penalty for each second or part of a second in excess of the time allowed, up to the time limit, which is twice the time allowed. Exceeding the time limit involves elimination.

## **Article 673 – TIME CORRECTIONS**

### **1. Knock-down with Disobedience**

- 1.1 If, as a result of a disobedience, an Athlete displaces or knocks down an obstacle or a flag defining the limits of the obstacle, the bell is rung. The clock is stopped until the obstacle has been rebuilt or the flag replaced. The Athlete will be penalised for a refusal and 6 seconds will be added to the time taken by the Athlete to complete his test.
- 1.2 If an Athlete displaces or knocks down one of the elements of a combination or a flag defining the limits of an element and refuses or runs out at one of the subsequent elements, the bell is rung. The clock will be stopped as for an obstacle knocked down following a disobedience. The penalties for the disobedience and the addition of 6 seconds must be applied.

### **2. Knock-down & Fall**

- 2.1. If there is a knock-down and a fall of Athlete together with a disobedience, the bell is rung immediately. However, the clock must be stopped only when the Athlete has remounted and only if the obstacle has not been rebuilt in time for the Athlete to continue his test. The Athlete will be penalised for a disobedience and a fall, and six seconds will be added to the time of the Athlete.
- 2.2. If, when jumping a single obstacle or the last part of a combination, there is a knock-down and a fall of Athlete, the clock must not be stopped and the judge must not ring the bell. The Athlete will be penalised for the fall and for knocking down the obstacle.
- 2.3. If, when jumping any element of a combination except the last, there is a knock-down and a fall, the bell is rung immediately. The clock must be stopped only when the Athlete has remounted and only if the obstacle has not been rebuilt in time for the Athlete to continue his test. The Athlete will be penalised for the fall and knocking down the obstacle.
- 2.4. If, at the second or third element of a combination, the refusal or run-out is the consequence of a fall with or without a knock-down and/or a displacement of obstacle and/or flag, no penalty is incurred for the disobedience. The 6 seconds of time corrections are not added to his time. The Athlete will be penalised only for his fall.

# **CHAPTER XI**

## **SPECIAL COMPETITIONS**

### **Article 674 – NEW ZEALAND ONE DAY EVENT CHAMPIONSHIPS**

In each year, the ESNZ Eventing Board will select the date and venue of the New Zealand One Day Event Championships at which championship competitions will be held to determine the winners of the following trophies:

1. Forest Gate Trophy - Awarded to the winner of the championship class run under 3\* conditions.
2. Waiteko Trophy - Awarded to the highest placed eligible Horse of the championship class run under 2\* conditions.
3. Ferndale Trophy - Awarded to the highest placed eligible Horse of the championship class run under 1\* conditions.
4. Tait Trophy – Awarded to the highest placed eligible Horse of the championship class run under CNC105 conditions.

In 2, 3 and 4 above, the respective National One Day Event Championship title will be awarded to the highest placed combination where the Horse has achieved no more than two MER's at a level higher than that for which the National Championship title is being awarded.

Applications to hold the New Zealand One Day Event Championships should be addressed to the Sport Manager of ESNZ Eventing.

### **Article 675 – NEW ZEALAND YOUNG RIDER AND JUNIOR RIDER ONE DAY EVENT CHAMPIONSHIPS**

The ESNZ Eventing Board will select the date and venue of the New Zealand Junior and Young Rider One Day Event Championship in each year.

1. Charisma Trophy. Run under CIC2\* or CNC2\* conditions and open to Young Riders. If the Trial is held under CNC2\* condition, Young Riders must have a Qualifying Result in either a CIC1\* or a CNC2\* during the current calendar year in question or the 2 preceding calendar years.
2. Hoffman Trophy. Run under CIC1\* or CNC1\* conditions and open to Juniors.

Applications to hold the New Zealand Young Athlete and Junior Rider One Day Event Championship should be addressed to the Sport Manager of ESNZ Eventing.

### **Article 676 – NEW ZEALAND THREE DAY EVENT CHAMPIONSHIPS**

The ESNZ Eventing Board will select the dates and venues of the New Zealand Three Day Event Championships to be held each year. The following trophies will be awarded.

1. Wills Challenge Trophy - Awarded to the winner of the CCI 3\* class.
2. Piccadilly Trophy - Awarded to the winner of the CCI 2\* class.
3. Mamaku Trophy - Awarded to the winner of the CCI 1\* class.
4. Thomson Trophy – Awarded to the winner of the CCN105 class.

In 2, 3 and 4 above, the respective National Three Day Event Championship title will be awarded to the highest placed combination where the Horse has achieved no more than two MER's at a level higher than that for which the National Championship title is being awarded.

Applications to hold the New Zealand Three Day Event Championships should be addressed to the Sport Manager of ESNZ Eventing.

#### **Article 677 – INTER-ISLAND TEAMS COMPETITION**

1. An Inter-island team competition competing for the Atlantic Silvers Spurs will be held in conjunction with the New Zealand Three Day Event Championships.
2. The visiting team may nominate a total of four Horses (or three if a fourth Horse is not available) from any class or classes provided the host team has an equal number of Horses starting in the class or classes concerned. The host team will consist of the same number of Horses entered in the same class or classes as the Horses of the visiting team.
3. If either team is unable to nominate four Horses, each team will consist of three Horses of which the scores of the two best Horses will count. If either team is unable to nominate three Horses the competition will be cancelled.
4. The classification will be in accordance with Article 641.

## **Article 678 – NEW ZEALAND YOUNG RIDER AND JUNIOR RIDER THREE DAY EVENT CHAMPIONSHIPS**

The ESNZ Eventing Board will select the date and venue of the New Zealand Young Rider and Junior Rider Three Day Event Championship in each year.

1. Swarbrick Trophy. Run under CCI2\* Conditions and open to Young Riders.
  2. Lenamore Trophy. Run under CCI1\* conditions and open to Juniors.
- Applications to hold the New Zealand Young Rider And Junior Rider One Day Event Championship should be addressed to the Sport Manager of ESNZ Eventing.

# ANNEX 1 SADDLERY

## PERMITTED BITS FOR THE DRESSAGE TEST

Captions to plate showing permitted bits

### VARIOUS BRIDOON BITS

1. Ordinary bridoon bit
2. Bridoon bit with two joints
3. Egg-butt bridoon bit
4. Bridoon bit with cheeks or drop + cheek bridoon

### VARIOUS TYPES OF CURB BITS

5. Half moon curb bit
- 6+7. Curb bit with straight cheeks and port
8. Curb bit with port and sliding mouthpiece (Weymouth)
9. Variation of bits No 6+7
10. Curb bit with S-curved cheeks
11. Curb chain
12. Lip strap
13. Leather cover curb chain
14. Rubber cover for curb chain



**DRAWINGS PERMITTED BITS**

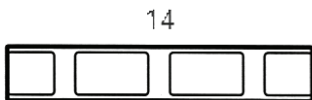
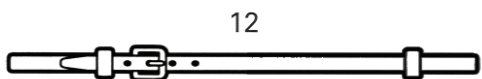
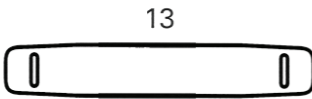
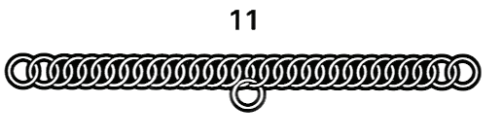
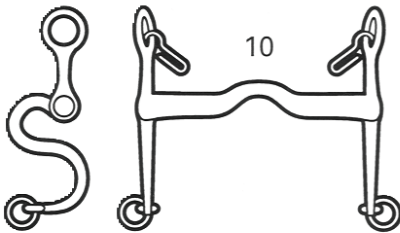
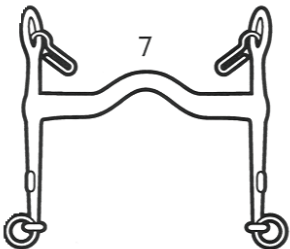
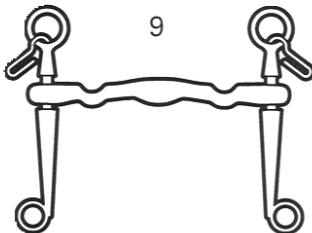
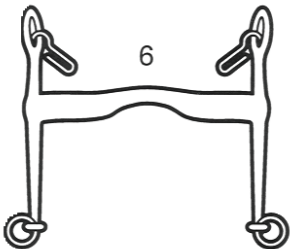
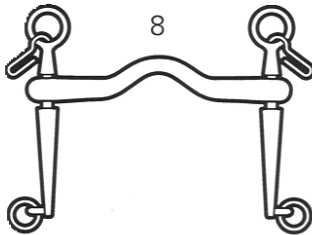
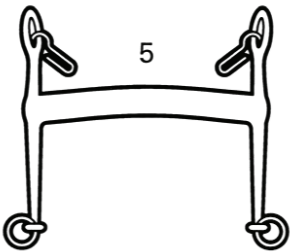
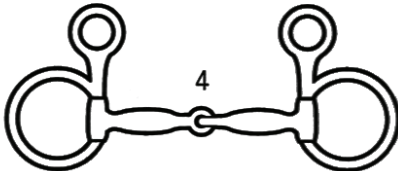
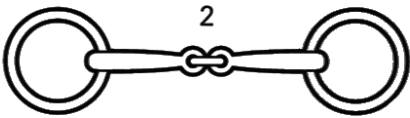
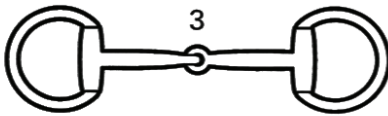
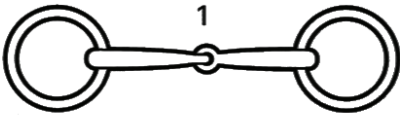

Note: all bridoon bits shown on the plate of permitted bits in both the “Rules for Eventing” and the “FEI Rules for Dressage Events” are permitted for the Dressage Test of Eventing either as a snaffle or as part of a double bridle.

A double bridle should always consist of a broken (simple or double) and a straight bit.

Bits can be made out of plastic or metal.

Any of the rings or cheeks shown on this plate are permitted with any of the bits.

An ordinary snaffle is a plain snaffle with a straight bar or joint in the centre.  
If a snaffle has two joints, all parts must be rounded and smooth.



In addition, the following types of snaffle are permitted:

1. Ordinary snaffle with double jointed mouthpiece
2. Ordinary snaffle with jointed mouthpiece
3. D-Rind or Racing snaffle – “D-Ring” (Not permitted as part of double bridle)
4. Egg-Butt Snaffle
  - (a) with cheeks (Tom Thumb)
  - (b) without cheeks
5. Other type of snaffle with cheeks (Fulmer)
6. Snaffle with upper cheeks only
7. Rubber, leather, rigid plastic or steel snaffle jointed or
- 8 Rubber, leather or plastic snaffle
8. Hanging cheek snaffle
9. Ordinary snaffle with double jointed mouthpiece with lozenge
10. Ordinary snaffle with double jointed mouthpiece (French link)
11. Unjointed wavy rigid plastic or rubber snaffle (not steel)
  - (a) with cheeks
  - (b) without cheeks
12. Ordinary snaffle with rotating mouthpiece
13. Snaffle with rotating middle piece

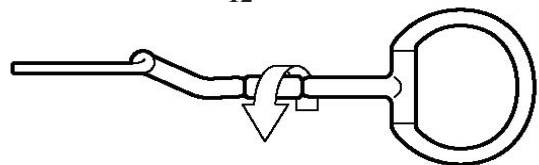
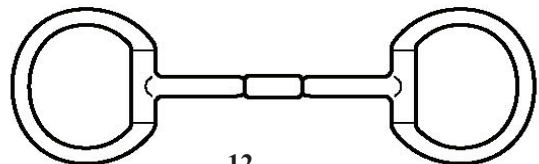
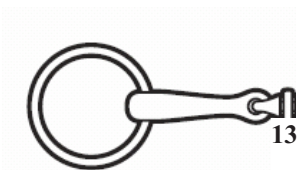
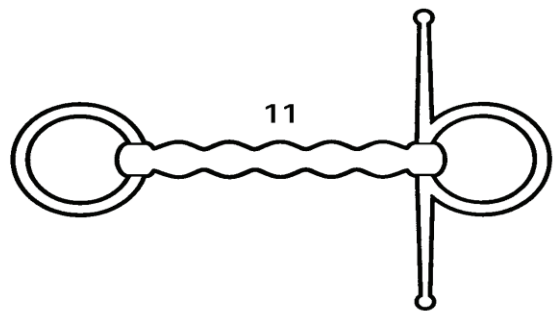
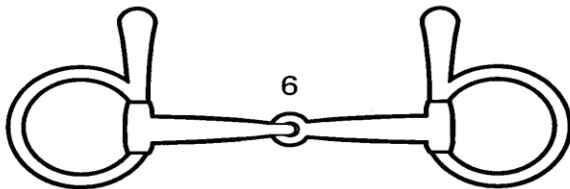
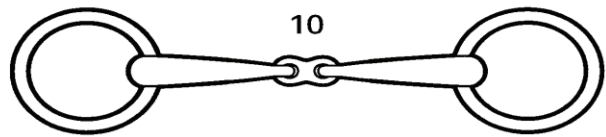
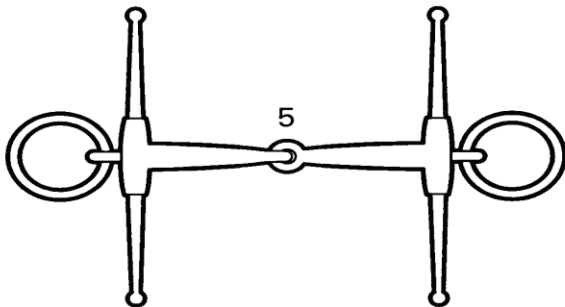
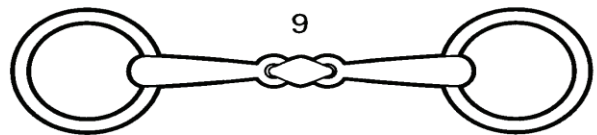
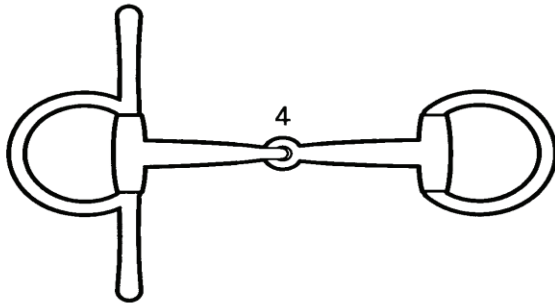
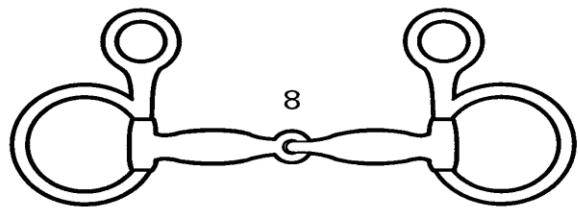
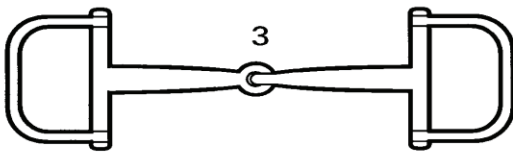
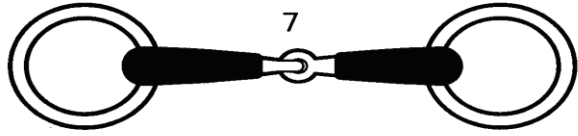
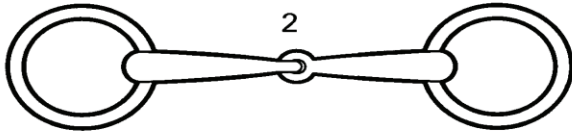
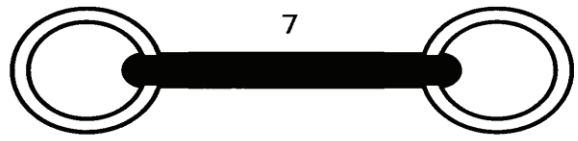
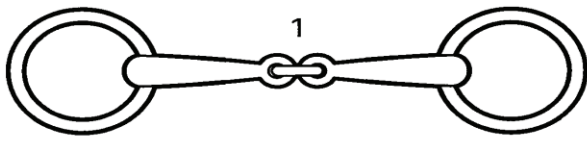
# DRAWINGS PERMITTED SNAFFLES

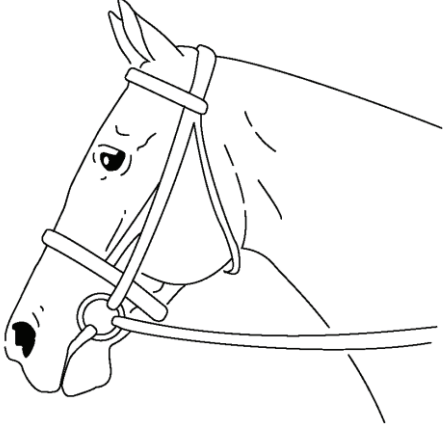
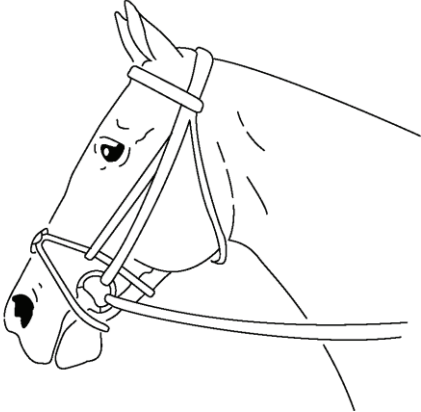
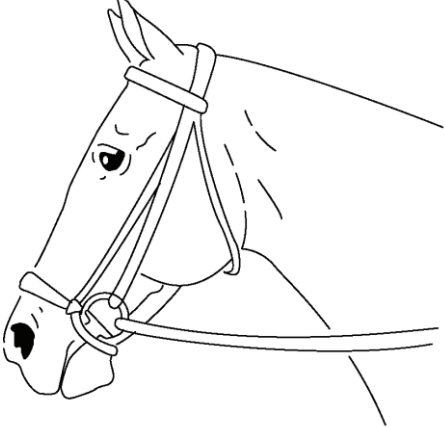
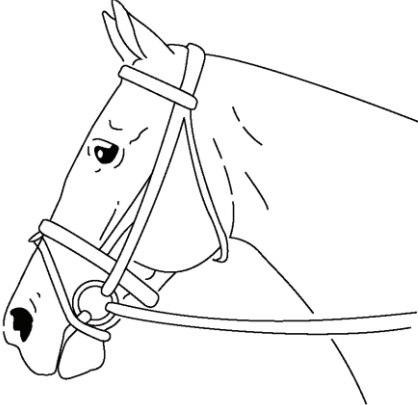
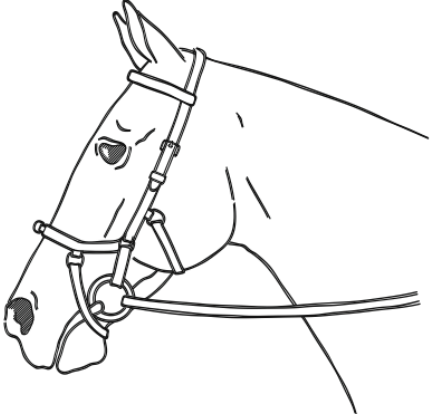

## PERMITTED NOSEBANDS FOR THE DRESSAGE TEST

1. Cavesson	2. Crossed noseband
	
	
3. Dropped noseband	4. Flash noseband
	
5. Micklem Bridle	6. Stotozem (combined noseband – no throat lash)

2, 3 and 4 are not permitted when a double bridle is used.

6 when used as a double bridle, the lower strap of the nose band is not allowed.

DRESSAGE ARENA (20m x 40m)  
Plan of 20m x 40m Arena

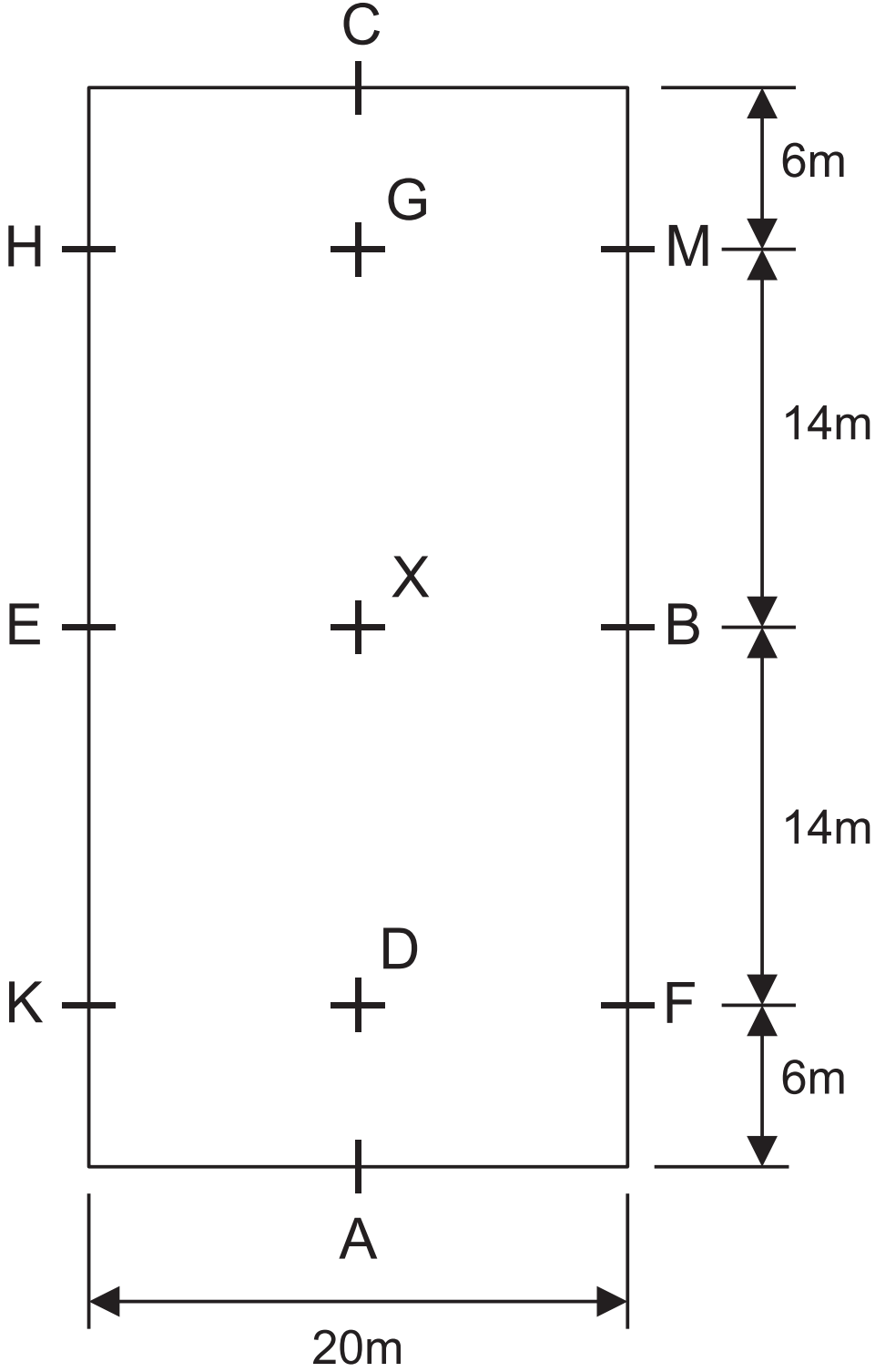

The length of the diagonal from corner to corner is 44.721m

DRESSAGE ARENA (20m x 60m)  
 Plan of 20m x 60m Arena

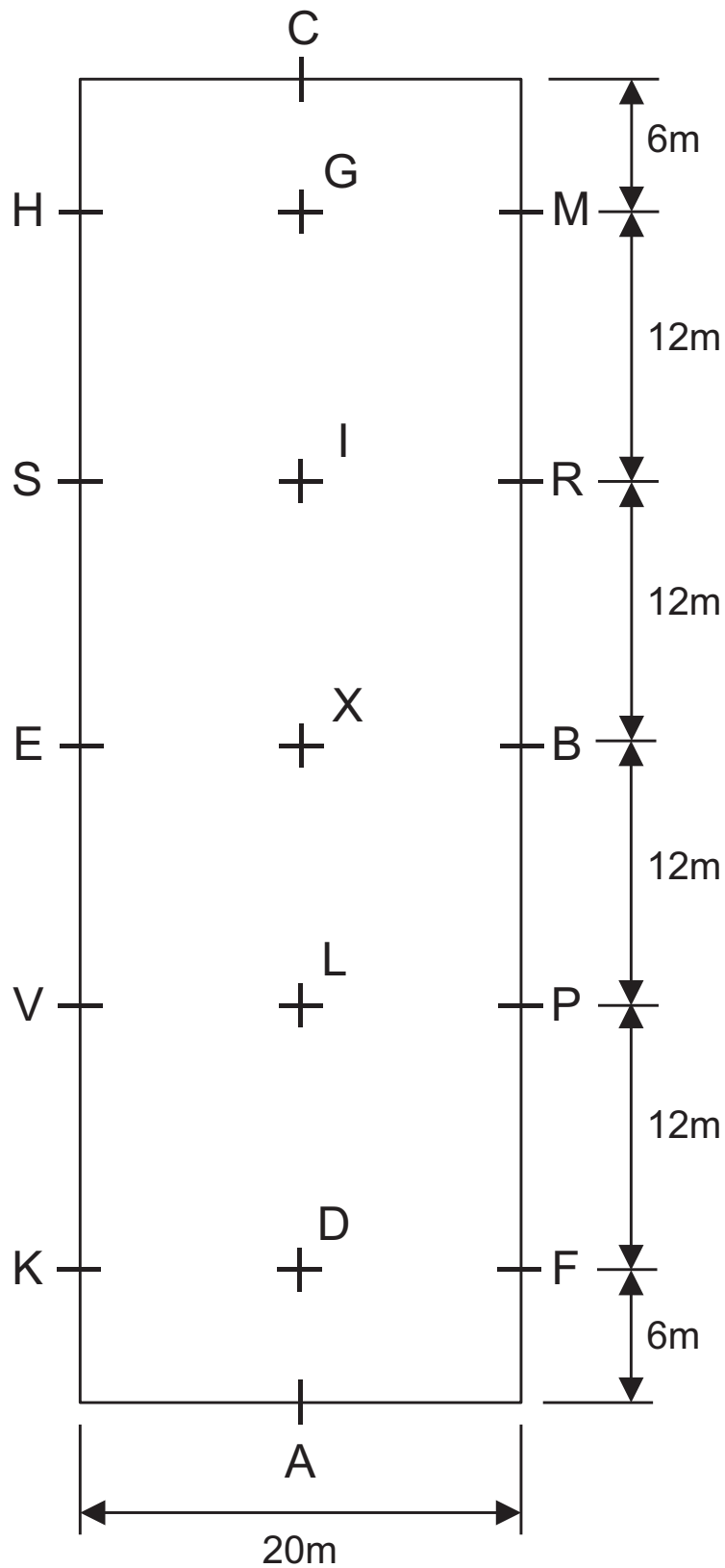

The length of the diagonal from corner to corner is 63.245m

# ANNEX 2 ONE DAY EVENTS

Class Indicators	White	Blue	Red	Black
<b>Cross Country</b>	CNC65 NZPC 65	CNC80 NZPC 80	CNC95 NZPC 95	CNC105 NZPC 105
<b>Maximum Height</b>	65cm	80cm	95cm	1.05m
<b>Brush</b>	75cm	90cm	1.15m	1.25m
<b>With height &amp; spread</b>				
Max Top Spread	75cm	90cm	1.05m	1.20m
Max Base Spread	1.00m	1.20m	1.50m	1.85m
<b>With Spread only</b>				
Max Spread without height	1.00m	1.20m	1.80m	2.40m
<b>Drop Fences</b>				
Max Drop	80cm	95cm	1.30m	1.40m
Max No / Max Drop	2/≥80cm	2/≥95cm	2/≥1.20m	2/≥1.30m
<b>Jumps into &amp; out of water</b>				
Max depth of water	Optional 20cm	20cm	20cm	20cm
<b>Distance</b>	1000 – 2000m	1400 – 2300m	1800 – 2500m	2000 – 2800m
<b>Speed</b>	300mpm	375mpm	425mpm	485mpm
<b>Maximum jump efforts</b> (Efforts 1 per 100m)	20	23	25	28
<b>Jumping</b>	CNC65 NZPC 65	CNC80 NZPC 80	CNC95 NZPC 95	CNC105 NZPC 105
<b>Max Height</b>	65cm	80cm	95cm	1.05m 1.10m (CNC105 Plus)
<b>Overall Spreads</b>				
Oxers	75cm	90cm	1.05m	1.15m
Triple Bar	95cm	1.10m	1.25m	1.35m
<b>Speed</b>	250mpm	300mpm	300mpm	325mpm
<b>Maximum Distance</b>	350m	450m	500m	500m
<b>No of Obstacles</b>	8	9	9	9
<b>Maximum efforts</b>	9	10	11	11
<b>Combination</b>	1 Double	1 Double	1 or 2 Doubles	2 Doubles
<b>Dressage</b>	CNC65 NZPC 65	CNC80 NZPC 80	CNC95 NZPC 95	CNC105 NZPC 95
<b>Tests</b>	Eventing L1 – L4 NZPCA Junior Riding Tests	Eventing L1 – L4 NZPCA Intermediate Riding Tests	Eventing L1 – L4, A1 – A4 NZPCA Intermediate Dressage Tests or NZPCA DC HT Tests	Eventing A1 – A4 & B1, B3, B4 (CNC105 Plus may use B2) NZPCA HT DC/A1 Tests

## ANNEX 2 ONE DAY EVENTS

Class Indicators	Yellow	Green	Blue
<b>Cross Country</b>	CNC 1* CNC 1* Plus NZPC A1	CNC 2* CNC 2* Plus	CNC 3*
<b>Max Height</b>	1.10m	1.15m	1.20m
<b>Brush</b>	1.30m	1.35m	1.40m
<b>With Height &amp; Spread</b>			
Max Top Spread	1.40m	1.60m	1.80m
Max Base Spread	2.10m	2.40m	2.70m
<b>With Spread only</b>			
Max Spread without height	2.80m	3.20m	3.60m
<b>Drop Fences</b>			
Max Drop	1.60m	1.80m	2.00m
Max No./ Max Drop	2 / ≥ 1.40m	2 / ≥ 1.60m	2 / ≥ 1.60m
<b>Jumps into &amp; out of water</b>			
Max depth of water	30cm	35cm	35cm
<b>Distance</b>	2000 – 3120m	2600 – 3575m	3000 – 3900m
<b>Speed</b>	520 mpm	550 mpm	570 mpm
<b>Maximum Jump Efforts</b>	30	32	35
<b>Jumping</b>	CNC 1* NZPC A1	CNC 1* Plus CNC 2*	CNC 2* Plus CNC 3*
<b>Max Height</b>	1.15m	1.20m	1.25m
<b>Overall Spreads</b>			
Oxers	1.30m	1.40m	1.45m
Triple Bar	1.50m	1.60m	1.65m
<b>Speed</b>	350 mpm	350 mpm	375 mpm
<b>Maximum Distance</b>	600m	600m	600m
<b>No. of Obstacles</b>	10 – 11	10 – 11	11 – 12
<b>Maximum Efforts</b>	13	14	15
<b>Combination</b>	2 or 3 Doubles or 1 Double & 1 Treble	2 or 3 Doubles or 1 Double & 1 Treble	2 or 3 Doubles or 1 Double & 1 Treble
<b>Dressage</b>	CNC105 Plus CNC 1* NZPC A1	CNC 1* Plus CNC 2*	CNC 2* Plus CNC 3*
<b>Tests</b>	Eventing B or FEI *	Eventing C or FEI **	Eventing D or FEI ***



## ANNEX 3 THREE DAY EVENTS

Class Indicators	Red	White	Yellow	Green	Blue
<b>Cross Country</b>	<b>CCN95</b>	<b>CCN105</b>	<b>CCN 1*</b>	<b>CCN 2*</b>	<b>CCN 3*</b>
<b>Max Height</b>	95cm	1.05m	1.10m	1.15m	1.20m
<b>Brush</b>	1.15m	1.25m	1.30m	1.35m	1.40m
<b>With Height &amp; Spread</b>					
Max Top Spread	1.05m	1.20m	1.40m	1.60m	1.80m
Max Base Spread	1.50m	1.80m	2.10m	2.40m	2.70m
<b>With Spread only</b>					
Max Spread without height	1.80m	2.40m	2.80m	3.20m	3.60m
<b>Drop Fences</b>					
Max Drop	1.25m	1.40m	1.60m	1.80m	2.00m
Max No./ Max Drop	2 / ≥ 1.00m	2 / ≥ 1.20m	2 / ≥ 1.40m	2 / ≥ 1.60m	2 / ≥ 1.60m
<b>Jumps into &amp; out of water</b>					
Max depth of water	20cm	20cm	30cm	35cm	35cm
<b>Distance</b>	2500 – 3000m	3000 – 4000m	3640 – 4680m	4400 – 5500m	5700 – 6270m
<b>Speed</b>	455 mpm	485 mpm	520 mpm	550 mpm	570 mpm
<b>Maximum Jump Efforts</b>	20-25	23-28	25-30	30-35	35-40
<b>Jumping</b>	<b>CCN95</b>	<b>CCN105</b>	<b>CCN 1*</b>	<b>CCN 2*</b>	<b>CCN 3*</b>
<b>Max Height</b>	1.00m	1.10m	1.15m	1.20m	1.25m
<b>Overall Spreads Oxers</b>	1.05m	1.20m	1.30m	1.40m	1.45m
<b>Triple Bar</b>	1.25m	1.40m	1.50m	1.60m	1.65m
<b>Speed</b>	300 mpm	325 mpm	350 mpm	350 mpm	375 mpm
<b>Maximum Distance</b>	500m	500m	600m	600m	600m
<b>No. of Obstacles</b>	9	9	10 – 11	10 – 11	11 – 12
<b>Maximum Efforts</b>	10	11	13	14	15
<b>Combination</b>	1 Double	2 Doubles	2 or 3 Doubles or 1 Double & 1 Treble	2 or 3 Doubles or 1 Double & 1 Treble	2 or 3 Doubles or 1 Double & 1 Treble
<b>Dressage</b>	<b>CCN95</b>	<b>CCN105</b>	<b>CCN 1*</b>	<b>CCN 2*</b>	<b>CCN 3*</b>
<b>Tests</b>	Eventing A	Eventing A or B	Eventing B or FEI *	Eventing C or FEI **	Eventing D or FEI ***

# ANNEX 4 XC FAULTS

If no refusal – 0 penalties  
 Art. 661.2  
 Original intention of Athlete

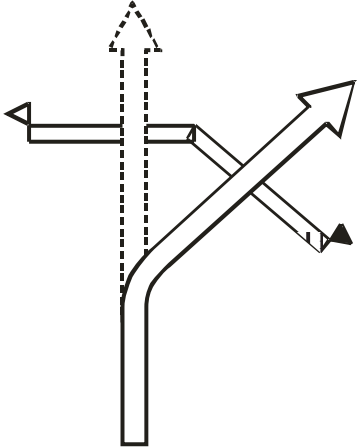

Change of intention by Athlete

0 penalties Art. 661.3.2

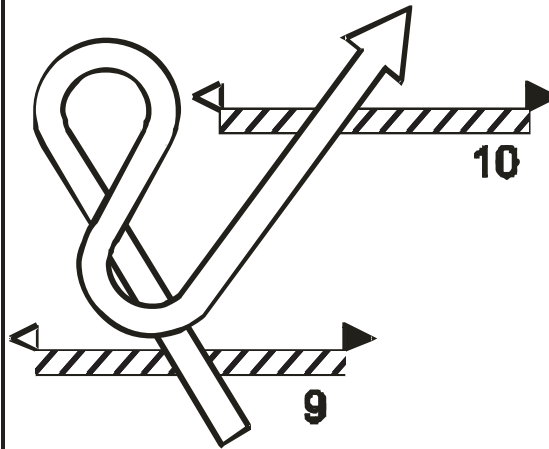

0 penalties Art. 661.3.2

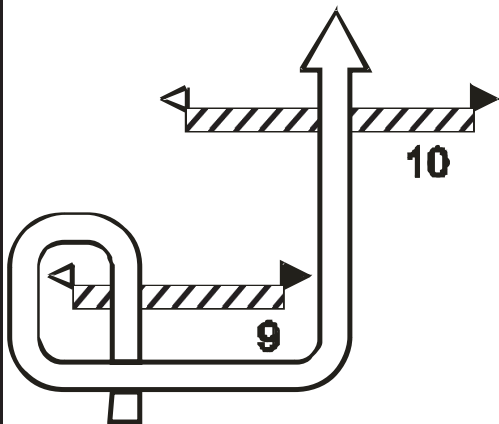

0 penalties  
 (unless presented at 10)  
 Art. 661.3.2

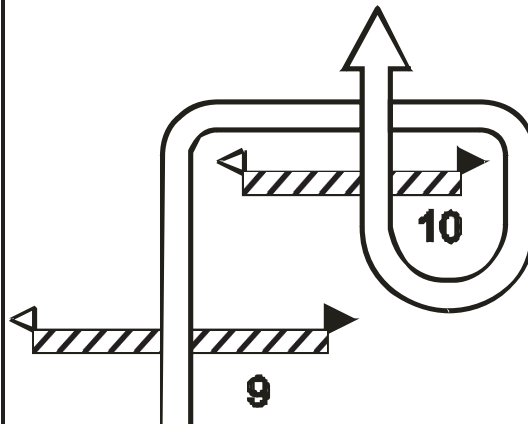

If presented – 20 penalties  
 Art. 661.3.1

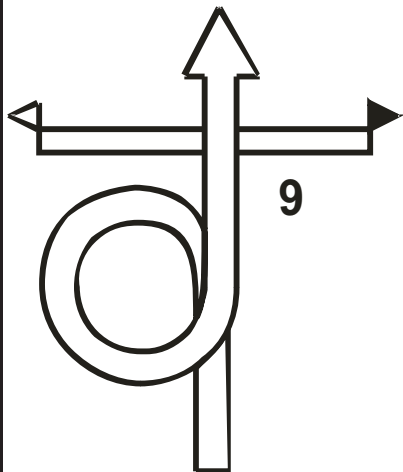

# Combinations

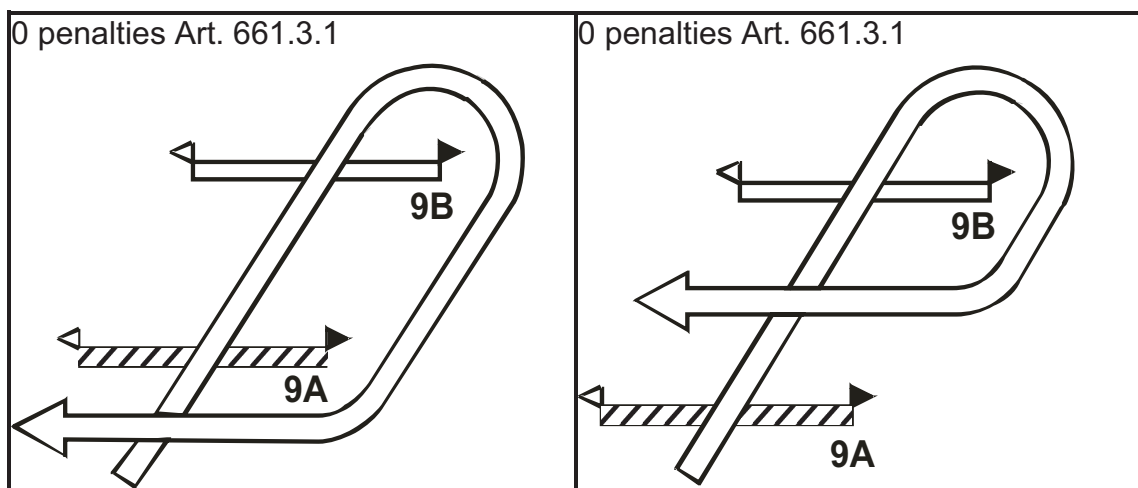
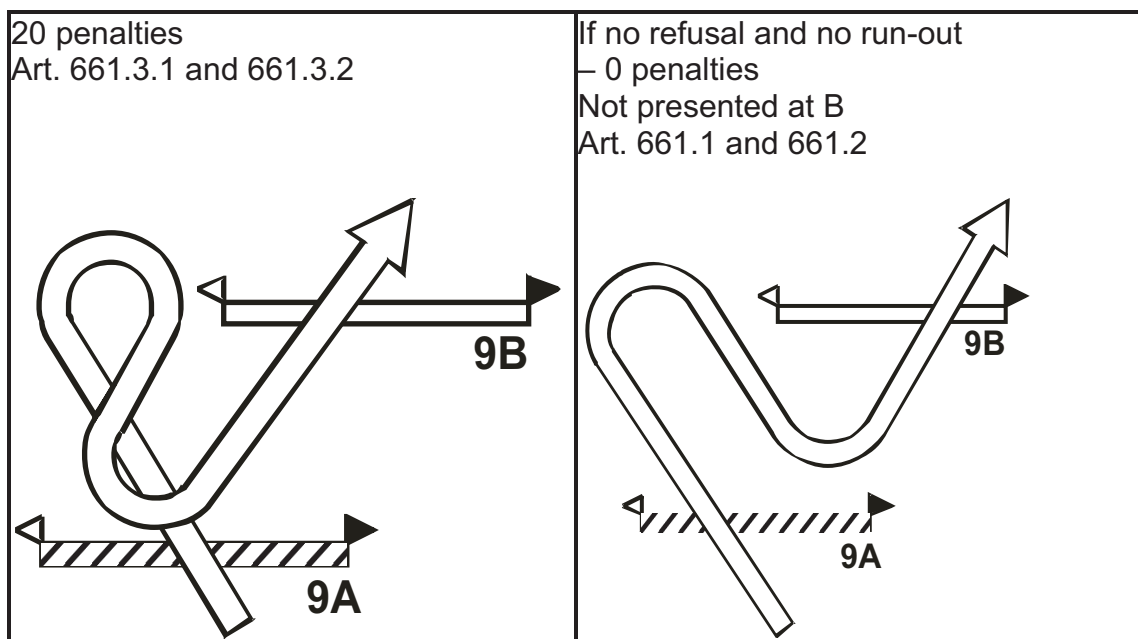
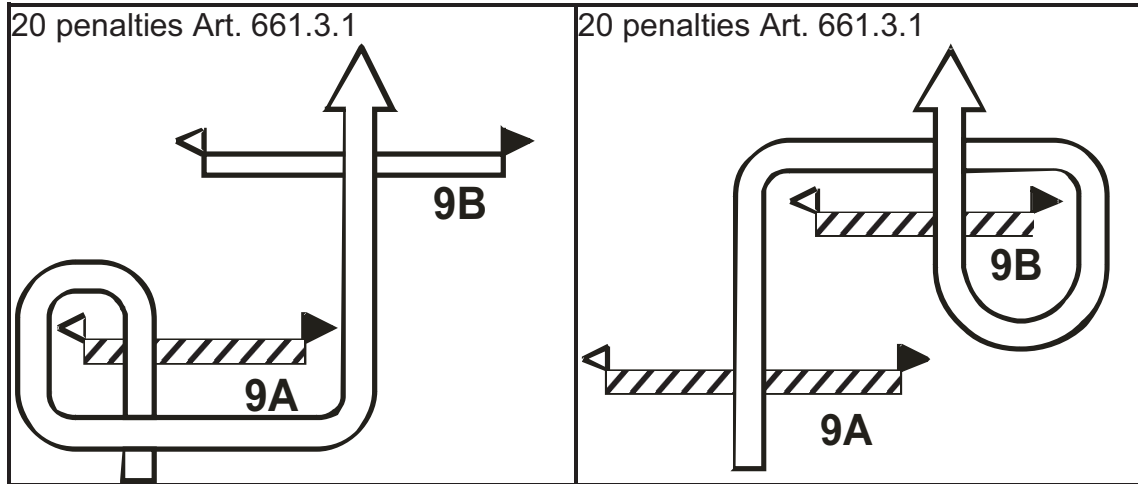

# Combinations

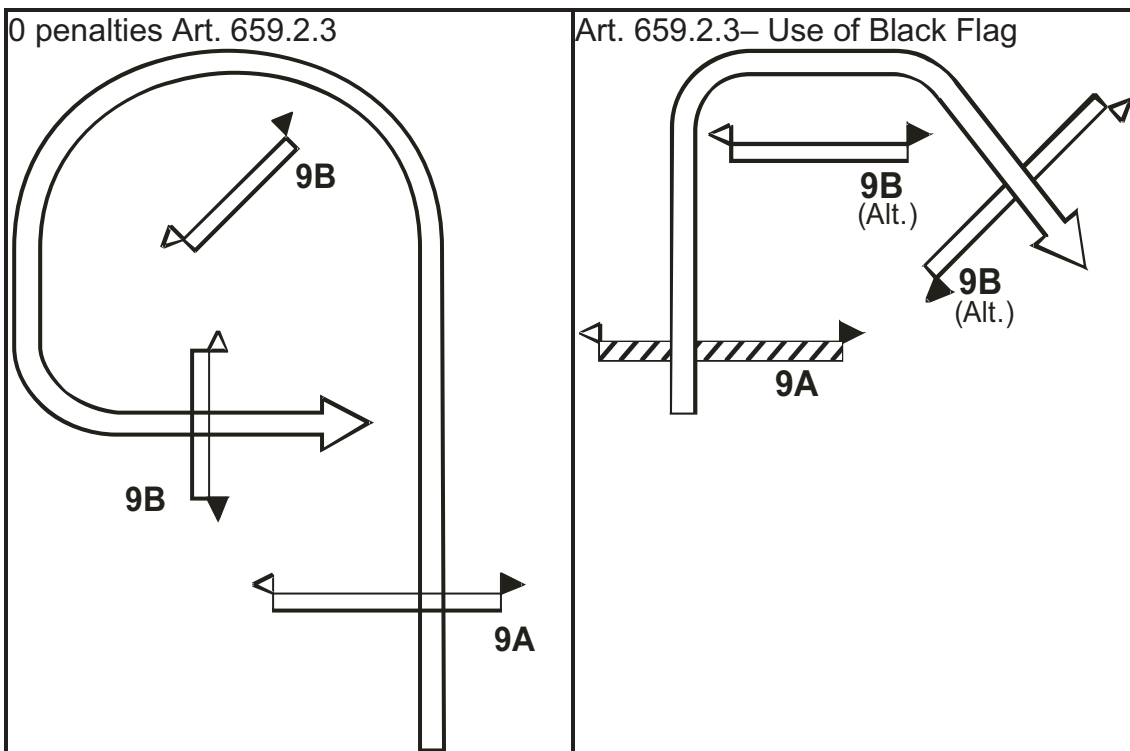
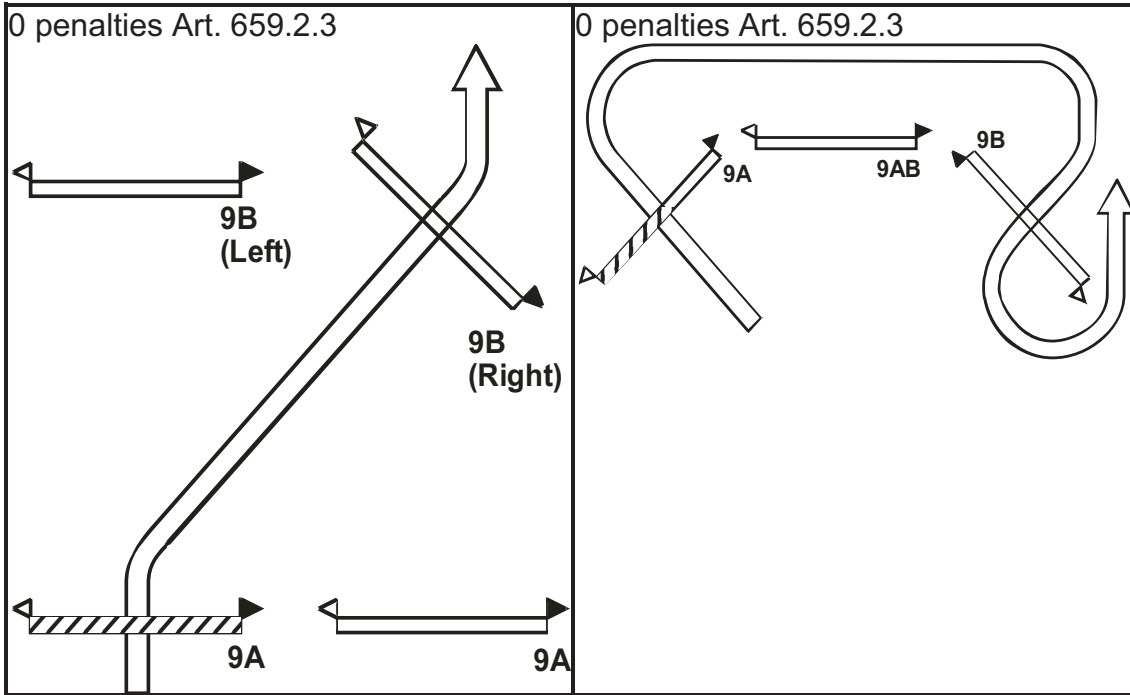

# ANNEX 5 NZPCA

## INTRODUCTION

The following exceptions or additional requirements to Eventing Rules exist for NZPCA Eventing competitions. Furthermore at Area Eventing Trials or NZPCA Eventing Championships please also refer to NZPCA Eventing Championship and Area Eventing Trials Regulations.

### Article 626 – TECHNICAL DELEGATE

1. A Pony Club TD or an ESNZ Level 3 TD can officiate up to NZPC-105 provided an ESNZ Level 2 or above Eventing TD or Eventing Judge is officiating as Chief Cross Country Judge for the event.
2. ESNZ Level 2 Eventing TD or above can officiate up to NZPC-A1, irrespective of the grade of the Chief Cross Country Judge.

### Article 635 – MINIMUM STANDARD FOR MEDICAL PERSONNEL AND SERVICES AT EVENTS

1. Refer to NZPCA General Regulations for full requirements. At any Pony Club Eventing competition (ODE/2DE) excluding Area Eventing Trials and NZPCA Eventing Championships the minimum medical cover required by test during the event is set out below:

Level of Competition	Dressage Test	Jumping Test	Cross Country Test Option 1	Cross Country Test Option 2
NZPC 65	First Aider	First Aider	First Aider & Ambulance Officer & Ambulance	First Aider & Paramedic & Ambulance
NZPC 80	First Aider	First Aider	First Aider & Ambulance Officer & Ambulance	First Aider & Paramedic & Ambulance
NZPC 95	First Aider	First Aider & Ambulance Officer & Ambulance	First Aider & Ambulance Officer & Ambulance	First Aider & Paramedic & Ambulance
NZPC 105	First Aider	Ambulance Officer & Ambulance	Paramedic & Ambulance	Paramedic & Ambulance
NZPC A1	First Aider	Ambulance Officer & Ambulance	Paramedic & Ambulance	Paramedic & Ambulance
<ul style="list-style-type: none"> <li>• First Aider must hold a current first aid certificate</li> </ul>				

In rural areas the Rural Fire Service may be an alternative to Ambulance provided they have personnel with the necessary qualifications equivalent to an Ambulance officer and/or paramedic and carry appropriate equipment.

2. At Area Eventing Trials and NZPCA Eventing Championships refer to NZPCA Eventing Championship Regulations.

### **Article 637 – MINIMUM STANDARDS FOR VETERINARY SERVICES AT EVENTS**

See NZPCA General Regulations 24 for full requirements

1. At Eventing competitions where the maximum level is NZPC 95 (formally Training) or any events involving riding “across country” such as Show-Cross, Derbies, Gamblers, and the following additional requirements must be met:
  - i. The “Official Veterinarian” should, if possible, be present throughout the event/competition, although this is not mandatory, provided satisfactory arrangements have been made for the “Official Veterinarian” to be available “on call” directly by the event/competition organisers .
  - ii. The “Official Veterinarian” should be printed in the official programme for the event. The “Official Veterinarian” should ideally be an individual and not a veterinary practice.
  - iii. “On call” does not refer to any out of hours’ veterinary service but the ability that the “official veterinarian” can be contacted directly as available to attend any incident promptly.
2. In addition at any Eventing competitions, (excluding Area Eventing Trials and NZPCA Eventing Championships) at which the maximum level is NZPC 105 or NZPC A1 the “Official Veterinarian” must be present during the cross country test of Eventing competition.
3. At Area Eventing Trials and NZPCA Eventing Championships refer to ESNZ Eventing Rules Article 637.1.2 and 637.1.3. and NZPCA Eventing Championship & Area Eventing Trials Regulations.

### **Article 639 – DANGEROUS RIDING**

1. In addition to the immediate competition sanctions outlined under “Article 639 – Dangerous Riding” it will be up to the Chief Cross Country Judge in consultation with the Technical Delegate to decide if the level of the offending is such that the offender should also be referred to their local branch/club under the NZPCA Code of Conduct for Dangerous Riding.

## **Article 640 – ABUSE OF HORSE**

1. In addition to the immediate competition sanctions outlined under “Article 640 – Abuse of Horse” it will be up to the Chief Cross Country Judge in consultation with the Technical Delegate to decide if the level of the offending is such that the offender should also be referred to their local branch/club under the NZPCA Code of Conduct for Abuse of the Horse.

## **Article 655 – DRESS**

1. Protective Headgear- see NZPCA General Regulations for full requirements. All Athletes in Pony Club Events must have their helmet tagged to reflect that it is of the approved standard.
2. Dressage Test – Riding Jacket, white shirt with white or pale tie/stock and pale jodhpurs or Pony Club uniform in branch/club colours may be worn. For Area Eventing Trials and NZPCA Eventing Championships see appropriate Regulations.
3. Cross Country Test – A long sleeve shirt/jersey should be worn.
4. Jumping Test – Riding Jacket, white shirt with white or pale tie/stock and pale jodhpurs or Pony Club uniform in branch/club/area colours may be worn. For Area Eventing Trials and NZPCA Eventing Championships see NZPCA Eventing Championship and Area Eventing Trials Regulations.

## **Article 656 – SADDLERY**

1. Where a surcingle is used it must not restrict the release of the stirrup leathers from the bars.

## **Article 655 – DRESS & Article – 656 SADDLERY**

1. Inspection of Dress & Saddlery – All Gear Safety Inspections should be carried out with reference to current ESNZ Eventing Rules and current NZPCA General Regulations, any Gear Check Sheet is only a guide and does not supersede either the ESNZ Eventing Rules and NZPCA General Regulation.
  - a. Gear Safety Inspections are to be compulsory in all tests (Dressage, Showjumping & Cross Country) for levels NZPC 65 (formally Introductory) and NZPC 80 (formally Pre-Training).
  - b. Gear Safety Inspections to be compulsory for Cross Country test only at NZPC 95 (formally Training) and only needs to be undertaken at random for dressage and show jumping.
  - c. Gear Safety Inspections only needs to be undertaken at random from NZPC 105 (formally Open) and NZPC A1

- d. The person carrying out the Gear Safety Inspection must contact the competition's TD if there are any issues regarding a competitor's saddlery or dress for them to adjudicate if so required.

### **Article 665 – OBSTACLES**

1. A combination obstacle with a bounce must always provide an alternate route, at levels below NZPC 105.
2. O Option Jumps:  
A maximum of 4 O Option obstacles are allowed with a penalty of 10 points per obstacle (regardless of the number of efforts) (Max 40pp). O Option obstacles will have a lesser degree of difficulty and placed alongside or near the main obstacles. The main obstacle and the O Option will carry the same number however the O Option will be identified with an O around the number.

### **Article 666 – SCORING**

1. Fall of athlete on the XC Course - elimination.



# INDEX

- Advanced, 15, 72  
Advanced Intermediate, 15, 72  
Appeal Committee, 17, 26  
Applications, 61, 62, 63  
**Arena**, 38, 69, 70  
ARENA, 47
- Boots, 41
- Championships, 28, 61, 62  
Charisma Trophy, 61  
Circle, 56  
Classes, 11, 13, 41, 42, 59  
**Classification**, 32  
Competitor in difficulty, 55  
Course, 13, 16, 17, 18, 39, 49, 51, 58, 59  
Course Designer, 16, 17, 18, 51, 58  
Cross Country, 10, 13, 15, 16, 18, 20, 22, 27, 28, 36, 37, 72, 73
- Disclaimer of liability, 13  
Dismounting, 49  
Disqualification, 33  
Double bridle, 66  
Dress, 42  
Dressage, 8, 9, 10, 13, 14, 15, 16, 22, 25, 26, 28, 32, 35, 36, 37, 38, 41, 45, 46, 72, 73  
Dressage Test, 9, 13, 14, 22, 25, 26, 28, 32, 35, 36, 37, 38, 41, 45, 46
- Elimination, 50, 55  
Error of course, 55
- F.E.I. Rules, 7  
Falls, 54  
**Faults**, 54, 59  
Ferndale Trophy, 61  
flags, 38, 39, 44, 49, 50, 51, 54, 56, 57  
**Flags**, 50  
Foreign horses, 11  
Forest Gate Trophy, 61
- General, 14, 44, 50, 51, 58
- Ground Jury, 13, 16, 17, 18, 19, 26, 27, 28, 29, 33, 36, 38, 39, 40, 42, 44, 48, 49, 50, 55, 57, 58
- Hoffman Trophy, 61
- Interruptions, 39
- Judges, 15, 16, 19, 20, 45, 46  
Jumping, 7, 9, 10, 14, 16, 18, 22, 24, 26, 27, 28, 29, 32, 36, 37, 38, 39, 40, 41, 43, 54, 55, 58, 59, 71, 72, 73  
Junior, 11, 12, 61, 63, 71
- Lenamore Trophy, 63  
Letters, 50  
Liability, 13
- Mamaku Trophy, 62  
Modifications, 40
- Obstacles, 9, 38, 54, 59, 72, 73  
Officials, 13, 17, 19, 44, 57  
Optimum time, 48  
Overtaking, 49
- Pace**, 49  
Penalties, 74, 75, 76  
Picadilly Trophy, 62  
Prizes, 14  
Programmes, 13
- Refusal, 54, 55, 74, 75  
rope, 47  
Rules, 1, 7, 8, 9, 11, 13, 14, 16, 17, 38, 45, 50, 58, 59  
Run-out, 56, 75
- Schooling**, 37  
Sponsorship, 9  
Spurs, 41, 42, 62  
**Start**, 48, 50  
**Starting**, 36, 48  
Steward, 19, 20, 38, 42  
Swarbrick Trophy, 63
- Tait Trophy, 61

Technical Delegate, 13, 16, 17, 18, 19,  
20, 29, 36, 38, 39, 40, 45, 51, 57, 58  
Thomson Trophy, 62  
Time, 48, 54, 59  
Timetable, 13

Unauthorised assistance, 55

Veterinarian, 16, 17, 18, 20, 26, 27, 28,  
29

Whips, 40

Wills Challenge Trophy, 62

Young Riders, 61, 63